

- 1981 — STS-1 [FIRST FLIGHT, COLUMBIA]
- 1982
- 1983 — STS-14 (41-D)
- 1984 — STS-19 (51-A)
- 1984 — STS-20 (51-C)
- 1985 — STS-23 (51-D)
- 1985 — STS-25 (51-G)
- 1985 — STS-27 (51-I)
- 1986 — STS-33 (51-L) [CHALLENGER TRAGEDY]
- 1987
- 1988 — RETURN TO FLIGHT-1
- 1989 — STS-26R
- 1989 — STS-29R
- 1990 — STS-33R
- 1990 — STS-31R
- 1991 — STS-41
- 1991 — STS-39
- 1992 — STS-48
- 1992 — STS-42
- 1992 — J-1 (UPGRADE DOWNTIME)
- 1993 — STS-53
- 1993 — STS-56
- 1994 — STS-51
- 1994 — STS-60
- 1995 — STS-64
- 1995 — STS-63
- 1995 — STS-70
- 1996 — J-2 (UPGRADE DOWNTIME)
- 1997 — STS-82
- 1998 — STS-85
- 1998 — STS-91
- 1999 — STS-95
- 1999 — STS-96
- 2000 — STS-103
- 2001 — STS-92
- 2001 — STS-102
- 2002 — STS-105
- 2003 — STS-107 [COLUMBIA TRAGEDY]
- 2004 — J-3 (UPGRADE DOWNTIME)
- 2005 — RETURN TO FLIGHT-2
- 2006 — STS-114
- 2007 — STS-121
- 2007 — STS-116
- 2008 — STS-120
- 2008 — STS-124
- 2009 — STS-119
- 2009 — STS-128
- 2010 — STS-131
- 2011 — STS-133
- 2011 — STS-135 [FINAL FLIGHT, ATLANTIS]
- 2012



# Space Transportation System Orbiter Discovery (OV-103)

Discovery (OV-103), NASA's third Orbiter to join the fleet, was named after one of the two ships that were used by British explorer James Cook in the 1770s. It was the first Orbiter built solely for operations and not for testing and benefited from the knowledge gained from the construction, assembly and testing of the Orbiters Enterprise, Columbia and Challenger. When it was completed, Discovery was almost 7,000 pounds lighter than Columbia

Discovery arrived at the Kennedy Space Center in Florida on November 9, 1983. After checkout, testing and processing, it was launched on Aug. 30, 1984, for its first mission, 41-D, to deploy three communications satellites. Since its inaugural flight Discovery has completed 39 missions, more flights than any other orbiter in NASA's fleet, carried 252 crew members, spent 365 days in space and travelled over 148,000,000 miles.

Just like all of the orbiters, it has undergone some major modifications and upgrades over the years. Most of the improvements were made during periods when the Orbiters were out of flight rotation for their Orbiter Maintenance Down Periods or their Orbiter Major Modifications which lasted from a few months to over a year. Additional improvements were made during both Return to Flight work flows. A sample of the changes included improvements in steering and braking, the addition of the drag chute system, weight-saving modifications to the Thermal Protection System, installation of the Multifunction Electronic Display Subsystem in the flight-deck cockpit and the installation of an external airlock and docking system to facilitate docking with the International Space Station.

Discovery has the distinction of being chosen as the Return to Flight Orbiter twice. The first was for STS-26 in 1988, and the second when it carried the STS-114 crew on NASA's Return to Flight mission to the International Space Station (ISS) in July 2005. Other missions of note were STS-31R, the deployment of the Hubble Space Telescope (HST), STS-63, first female shuttle pilot and the first rendezvous and fly around by the shuttle of the space station Mir, STS-82 the second servicing of HST and highest altitude known for a shuttle flight at 360 statute miles, STS-95, the return of astronaut John Glenn to orbit as the oldest human to fly in space, STS-96, the first docking to the ISS and STS-103 the third HST servicing mission.

Discovery touched down for the final time at Kennedy Space Center at 11:57 am EDT, concluding STS 133, a mission to the International Space Station. Discovery was ferried atop the Shuttle Carrier Aircraft to the Smithsonian Institution's Air and Space Museum's Udvar-Hazy annex in Chantilly, Virginia where it is now on permanent display.

This recording project is part of the Historic American Engineering Record (HAER), a long-range program to document historically significant engineering, industrial, and maritime works in the United States. The HAER program is administered by the National Park Service, U.S. Department of the Interior. The Space Transportation System recording project was cosponsored during 2011 by the Space Shuttle Program Transition and Retirement Office of the Johnson Space Center (JSC), with the guidance and assistance of Barbara Severance, Integration Manager, JSC, Jennifer Groman, Federal Preservation Officer, NASA Headquarters and Ralph Allen, Historic Preservation Officer, Marshall Space Flight Center. The field work and measured drawings were prepared under the general direction of Richard O'Connor, Chief, Heritage Documentation Programs, National Park Service. The project was managed by Thomas Behrens, HAER Architect and Project Leader. The Space Transportation System Recording Project consisted architectural delineators, John Wachtel, Iowa State and Joseph Klimek, Illinois Institute of Technology. This documentation is based on high-definition laser scans provided by Smart GeoMetrics, Houston, Texas and documentation provided by NASA's Headquarters, Johnson Space Center and Marshall Space Flight Center. Written historical and descriptive data was provided by Archaeological Consultants Inc., Sarasota, Florida. Large-format photographs were produced by NASA's Imaging Lab at Johnson Space Center with supplemental images provided by Jet Lowe, HAER photographer.



Orbiter Discovery on orbit during STS-131. The Leonardo Multi-Purpose Logistic Module for the International Space Station is in its payload bay. Image courtesy of NASA Johnson Space Center. Photographer unknown

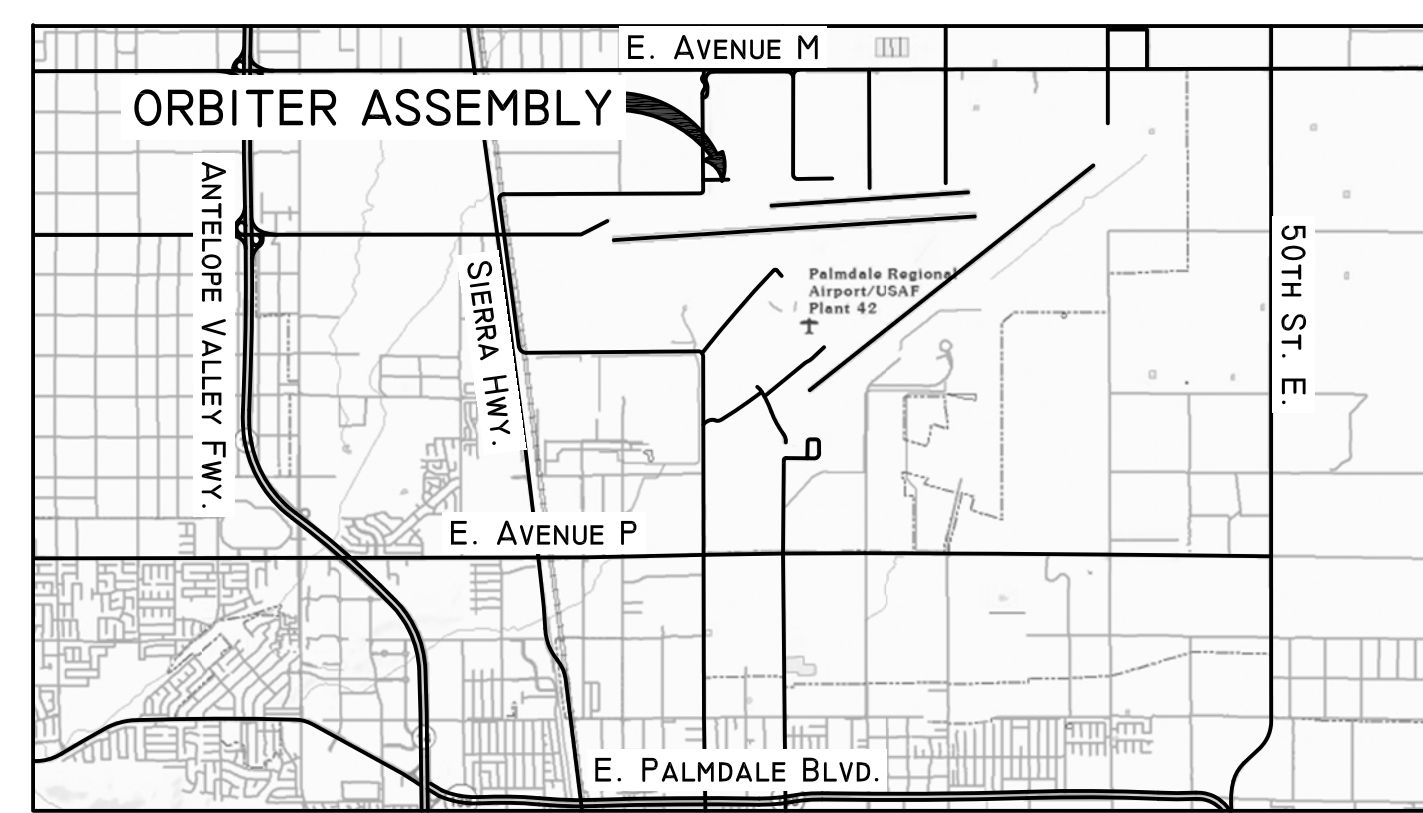

VICINITY MAP PALMDALE, CA

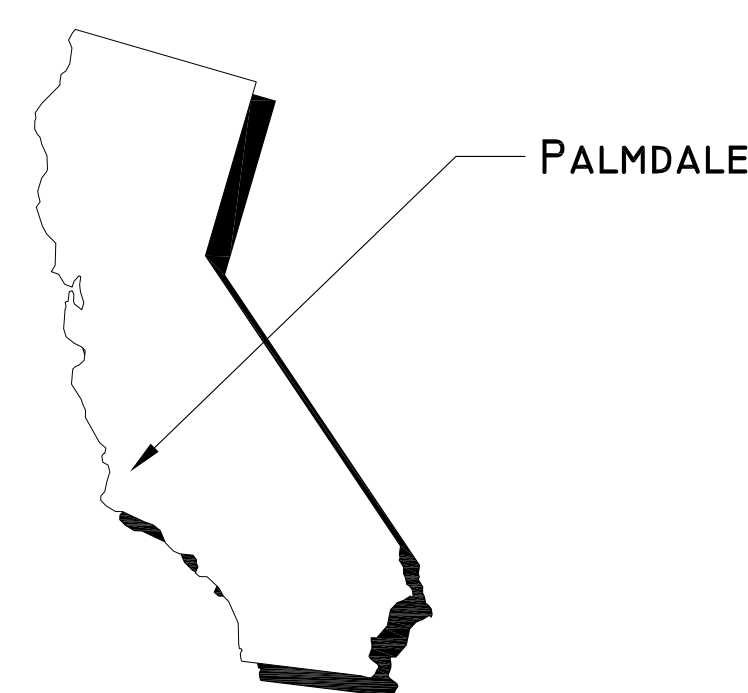

CALIFORNIA

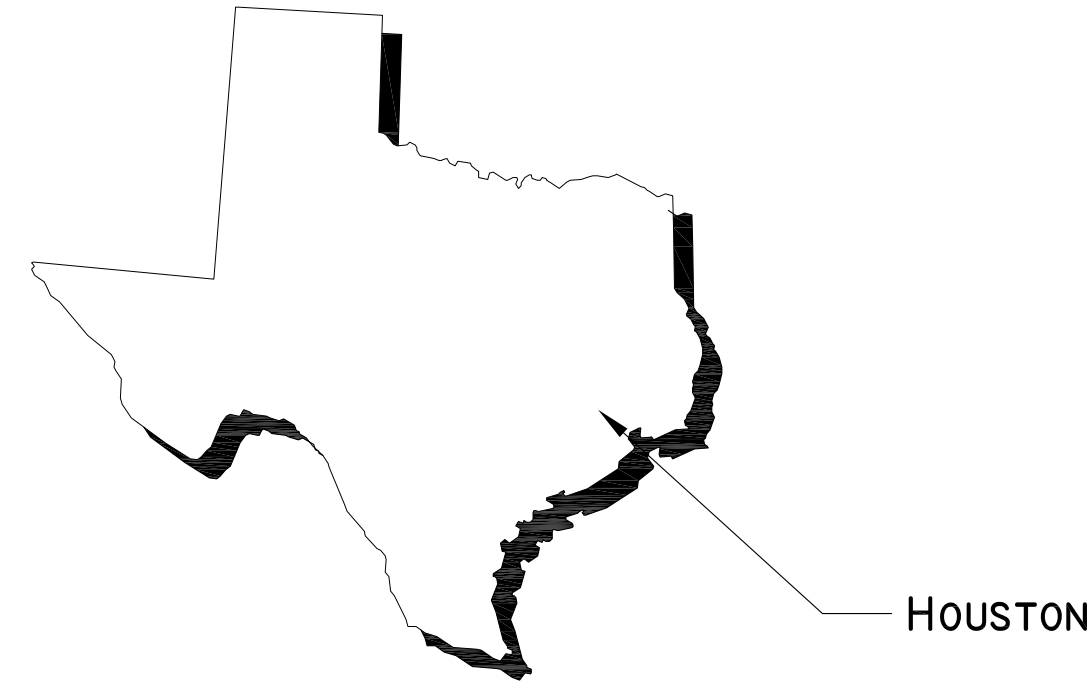

TEXAS

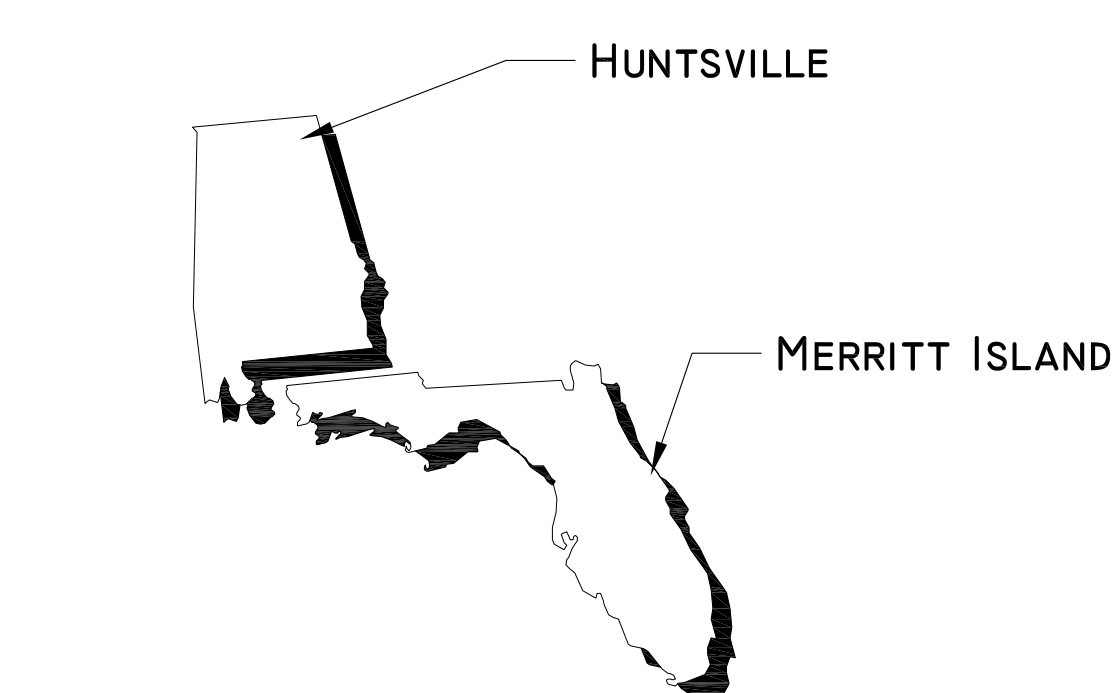

ALABAMA

FLORIDA

DELINEATED BY: THOMAS M. BEHRENS  
 SPACE TRANSPORTATION SYSTEM RECORDING PROJECT  
 NATIONAL PARK SERVICE  
 UNITED STATES DEPARTMENT OF THE INTERIOR  
 HOUSTON  
 SPACE TRANSPORTATION SYSTEM, ORBITER DISCOVERY (OV-103)  
 JOHNSON SPACE CENTER, 2101 NASA PARKWAY  
 HARRIS COUNTY  
 TEXAS  
 SHEET 01 OF 15  
 HISTORIC AMERICAN ENGINEERING RECORD  
 TX-116-A  
 LIBRARY OF CONGRESS  
 INDEX NUMBER

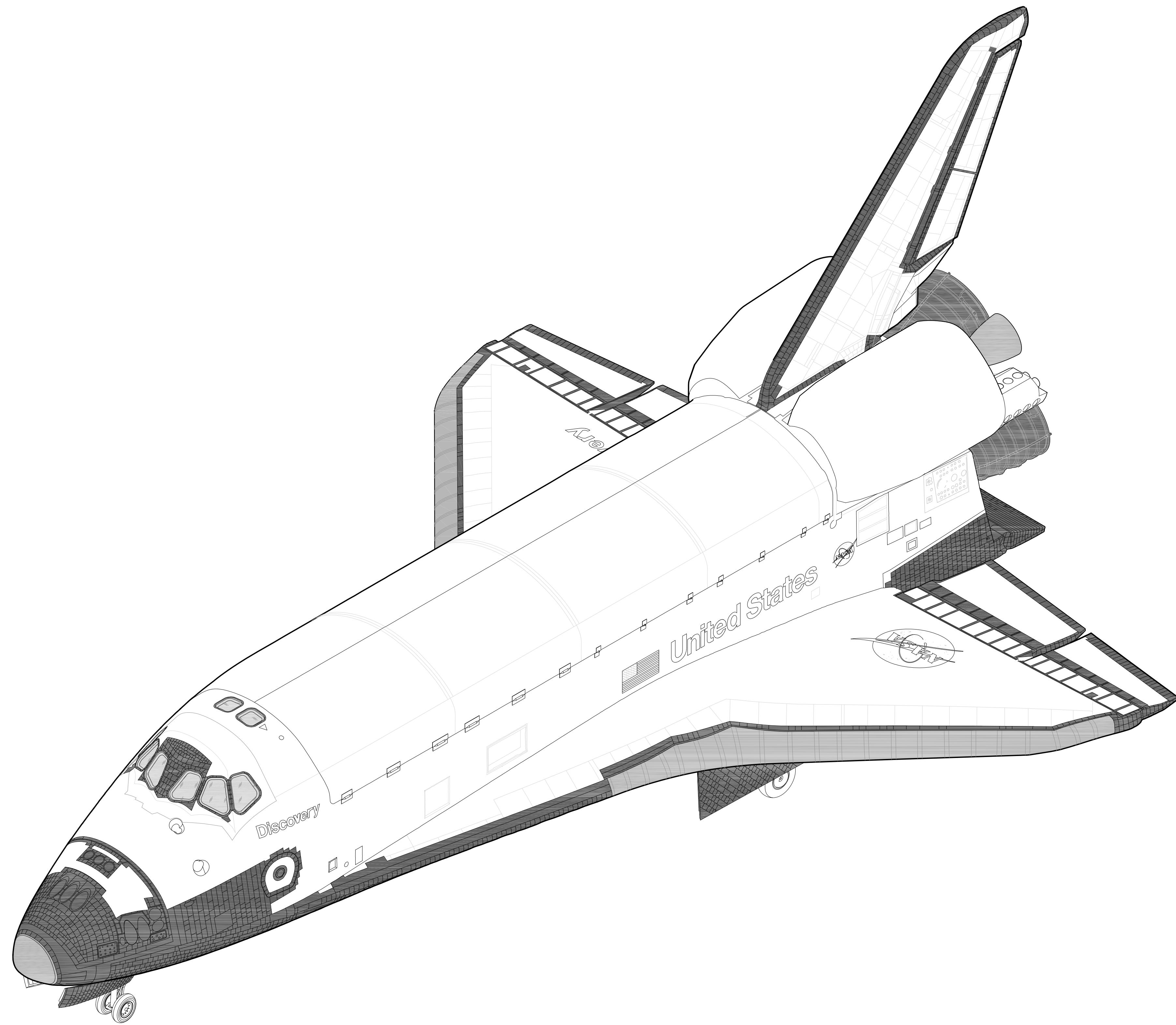

PORT ISOMETRIC

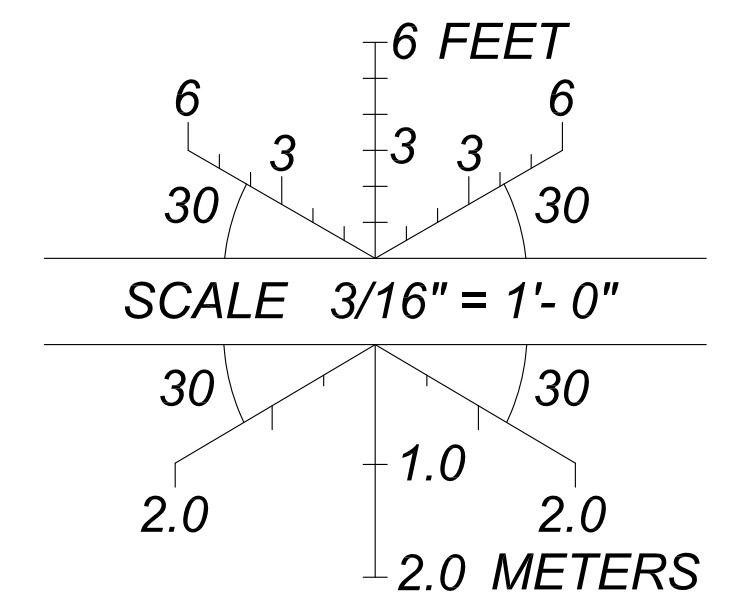

DELINATED BY: JOHN WACHTEL, JOSEPH KLIMEK  
 SPACE TRANSPORTATION SYSTEM  
 RECORDING PROJECT  
 NATIONAL PARK SERVICE  
 UNITED STATES DEPARTMENT OF THE INTERIOR

HOUSTON

SPACE TRANSPORTATION SYSTEM, ORBITER DISCOVERY (OV-103)  
 JOHNSON SPACE CENTER, 2101 NASA PARKWAY  
 HARRIS COUNTY

TEXAS 02 OF 15

HISTORIC AMERICAN  
 ENGINEERING RECORD  
 TX-116-A

LIBRARY OF CONGRESS  
 INDEX NUMBER

IF REPRODUCED PLEASE CREDIT THE HISTORIC AMERICAN ENGINEERING RECORD, NATIONAL PARK SERVICE, NAME OF DELINEATOR, DATE OF DRAWING

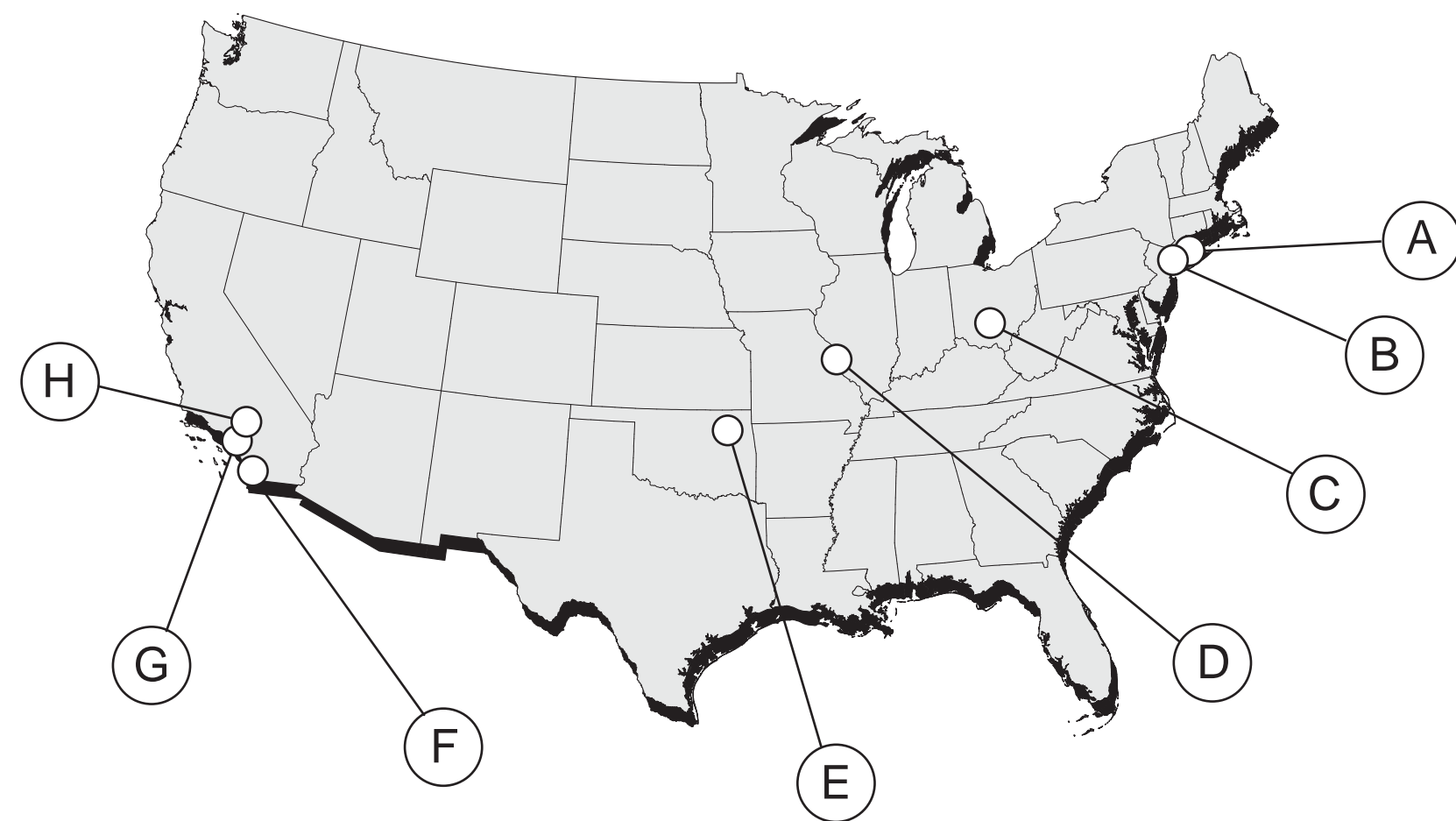

MAJOR MANUFACTURING LOCATIONS

- (A) FAIRCHILD REPUBLIC FARMINGDALE, NY  
-VERTICAL TAIL
- (B) GRUMMAN BETHPAGE, NY  
- WINGS
- (C) NORTH AMERICAN ROCKWELL COLUMBUS, OH  
- BODY FLAP
- (D) MCDONNELL DOUGLAS ST. LOUIS, MO  
- OMS PODS
- (E) NORTH AMERICAN ROCKWELL TULSA, OK  
- ORBITER PAYLOAD BAY DOORS
- (F) GENERAL DYNAMICS SAN DIEGO, CA  
- ORBITER MID FUSELAGE
- (G) NORTH AMERICAN ROCKWELL DOWNEY, CA  
- AFT FUSELAGE  
- FWD. FUSELAGE (UPPER AND LOWER)  
- CREW COMPARTMENT  
- FWD. REACTION CONTROL SYSTEM
- (H) NORTH AMERICAN ROCKWELL PALMDALE, CA  
- FINAL ASSEMBLY

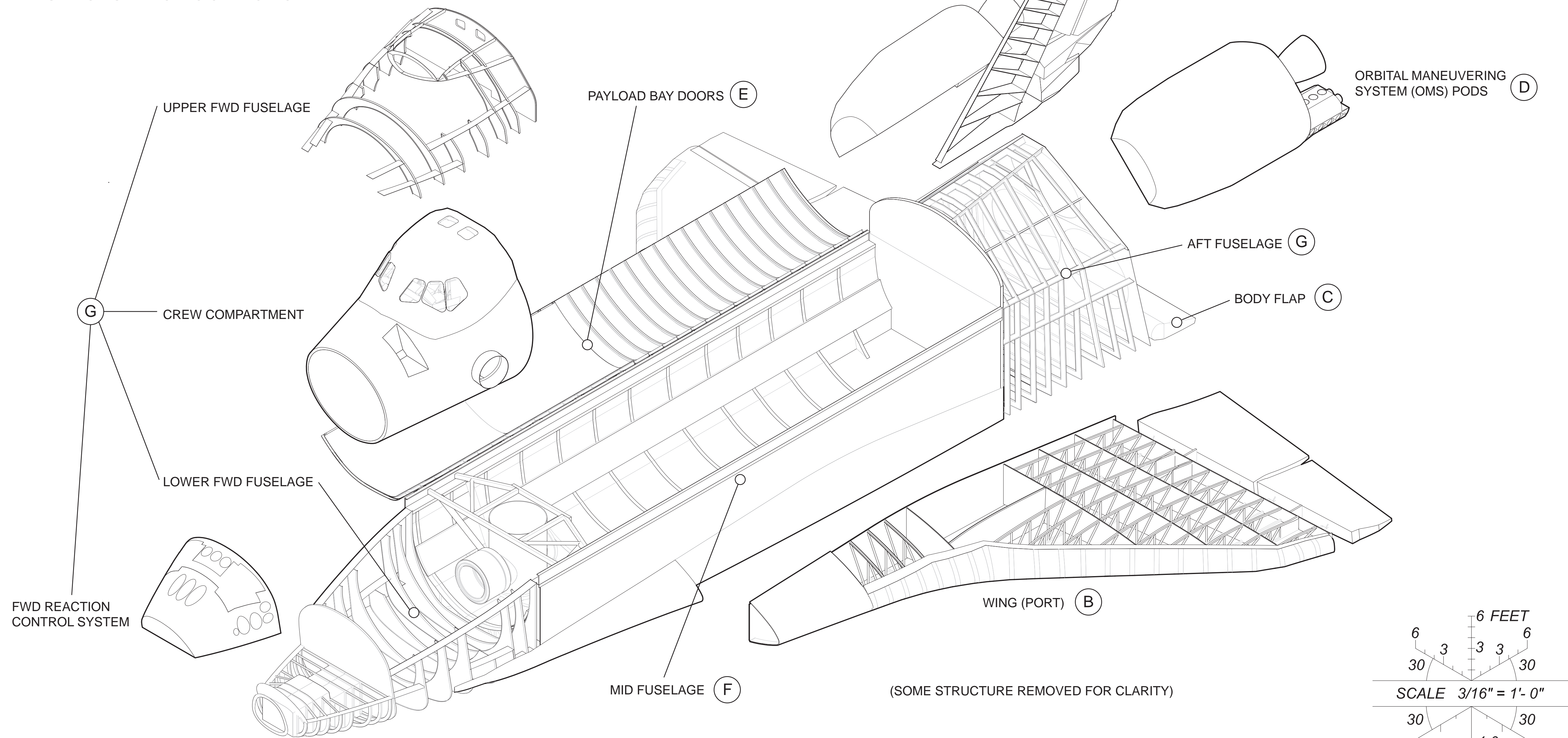

**COMPONENT ISOMETRIC**

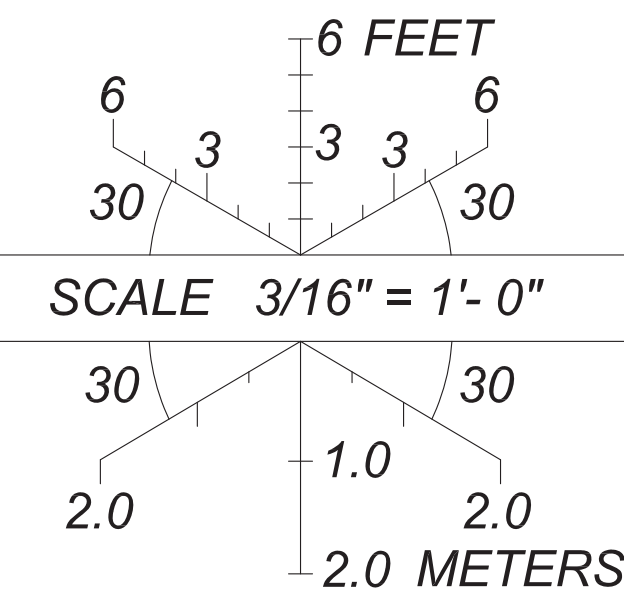

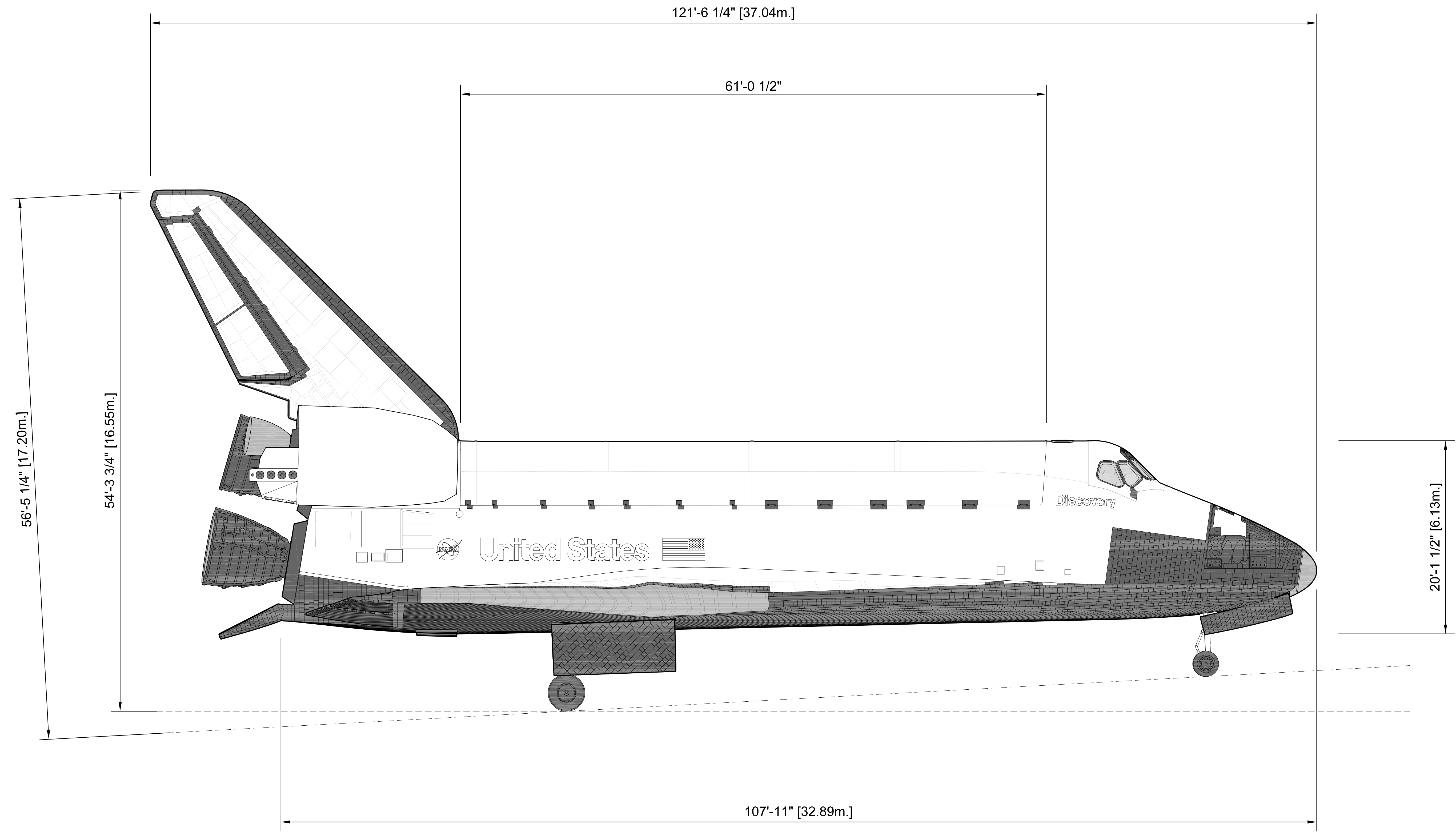

# STARBOARD ELEVATION

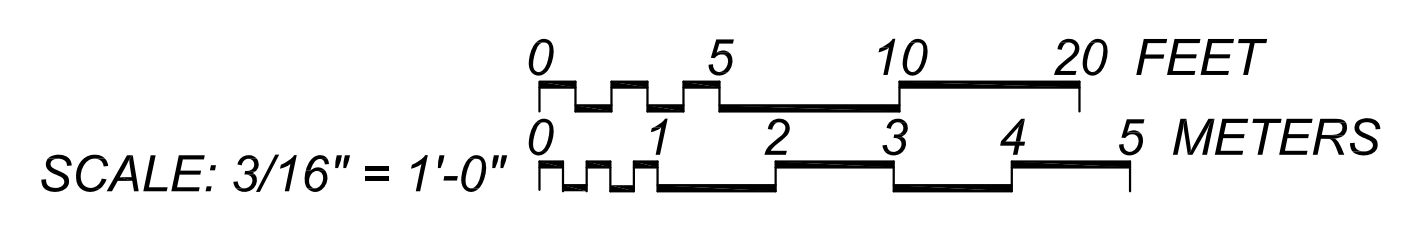

DELINEATED BY: JOHN WACHTEL, JOSEPH KLIMEK  
 SPACE TRANSPORTATION SYSTEM  
 RECORDING PROJECT  
 NATIONAL PARK SERVICE  
 UNITED STATES DEPARTMENT OF THE INTERIOR

HOUSTON

SPACE TRANSPORTATION SYSTEM, ORBITER DISCOVERY (OV-103)  
 JOHNSON SPACE CENTER, 2101 NASA PARKWAY  
 HARRIS COUNTY

TEXAS

SHEET 04 OF 15

INDEX NUMBER  
 TX-116-A

IF REPRODUCED PLEASE CREDIT THE HISTORIC AMERICAN ENGINEERING RECORD, NATIONAL PARK SERVICE, NAME OF DELINEATOR, DATE OF DRAWING

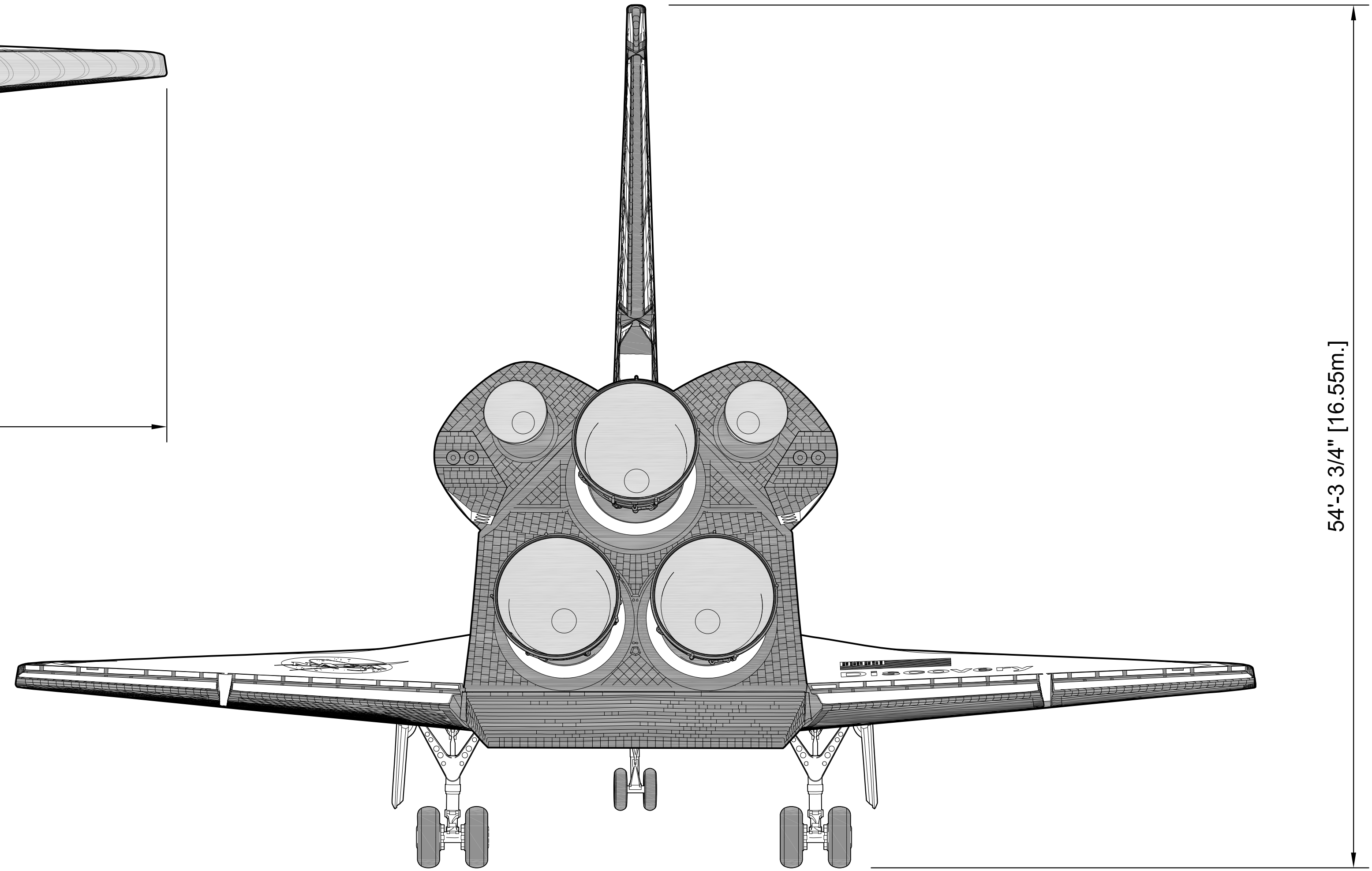
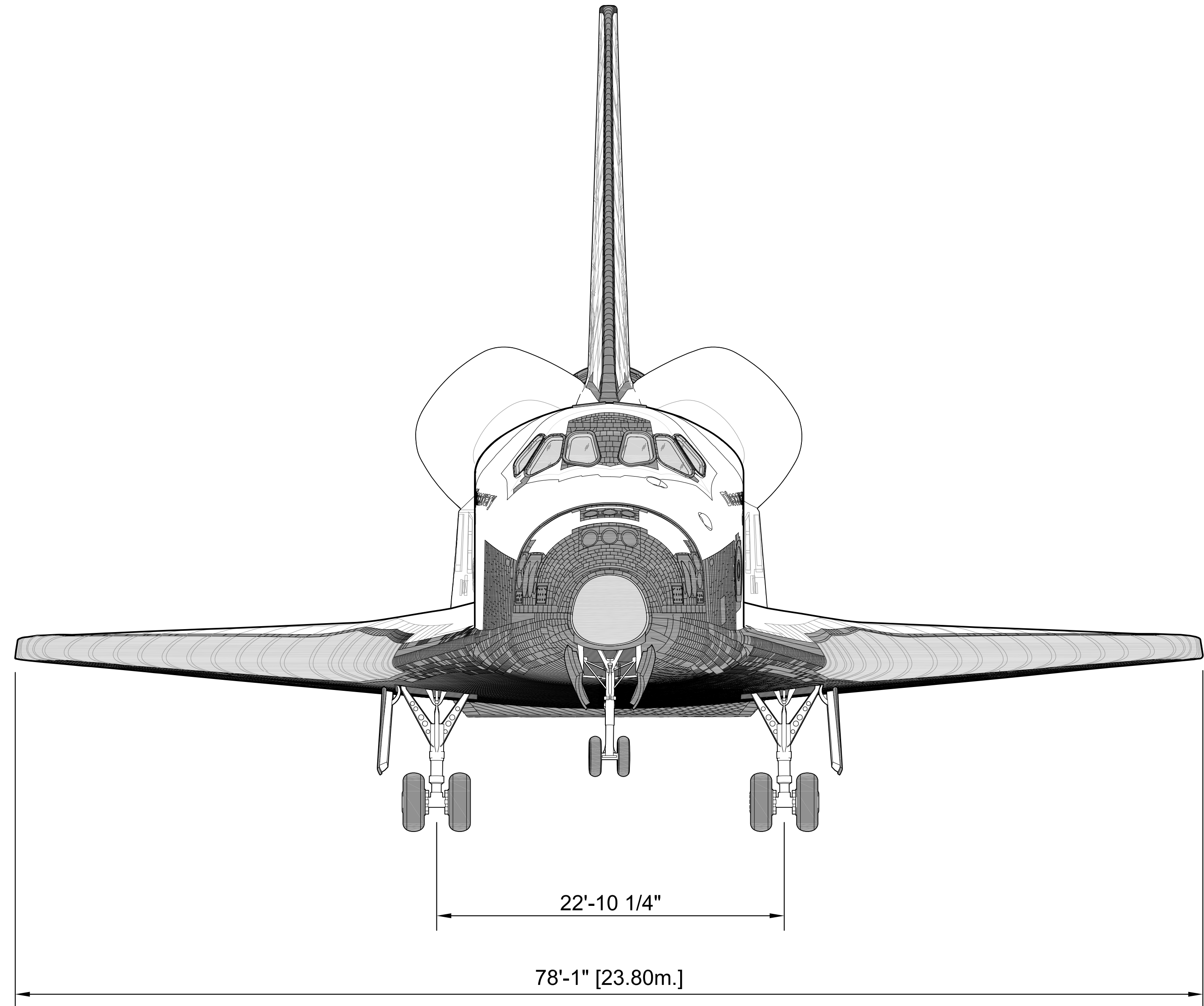

# FWD AND AFT ELEVATIONS

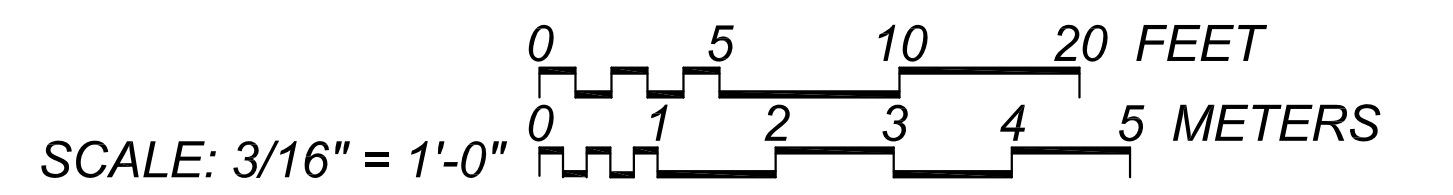

DELINEATED BY: JOHN WACHTEL, JOSEPH KLIMEK  
 SPACE TRANSPORTATION SYSTEM  
 RECORDING PROJECT  
 NATIONAL PARK SERVICE  
 UNITED STATES DEPARTMENT OF THE INTERIOR

HOUSTON

SPACE TRANSPORTATION SYSTEM, ORBITER DISCOVERY (OV-103)  
 JOHNSON SPACE CENTER, 2101 NASA PARKWAY  
 HARRIS COUNTY

TEXAS

SHEET 05 OF 15

HISTORIC AMERICAN  
 ENGINEERING RECORD  
 INDEX NUMBER  
 TX-116-A

IF REPRODUCED PLEASE CREDIT THE HISTORIC AMERICAN ENGINEERING RECORD, NATIONAL PARK SERVICE, NAME OF DELINEATOR, DATE OF DRAWING

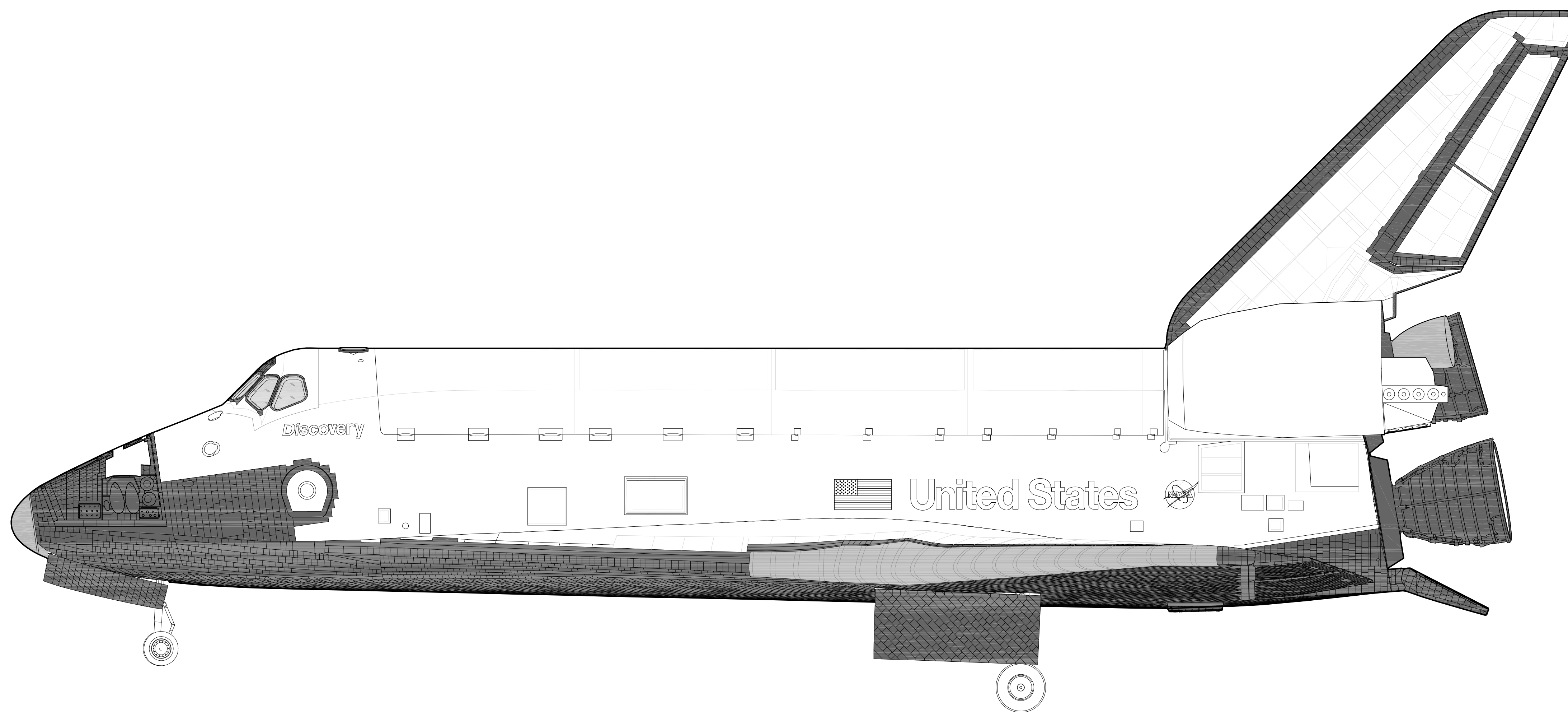

PORT ELEVATION

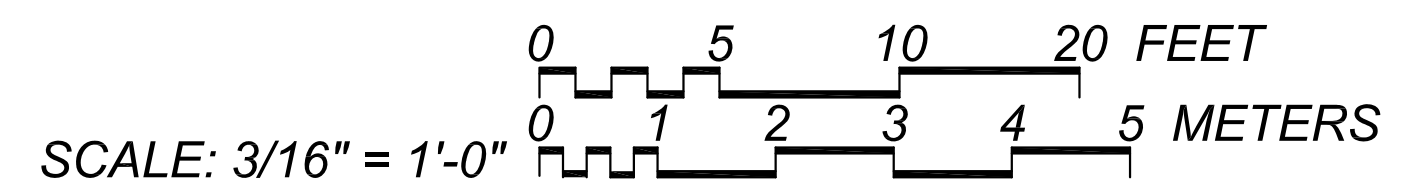

DELINEATED BY: JOHN WACHTEL, JOSEPH KLIMEK

SPACE TRANSPORTATION SYSTEM  
RECORDING PROJECT  
NATIONAL PARK SERVICE  
UNITED STATES DEPARTMENT OF THE INTERIOR

HOUSTON

SPACE TRANSPORTATION SYSTEM, ORBITER DISCOVERY (OV-103)  
JOHNSON SPACE CENTER, 2101 NASA PARKWAY  
HARRIS COUNTY

TEXAS

SHEET 06 OF 15  
HISTORIC AMERICAN  
ENGINEERING RECORD

TX-116-A  
INDEX NUMBER

IF REPRODUCED, PLEASE CREDIT THE HISTORIC AMERICAN ENGINEERING RECORD, NATIONAL PARK SERVICE, NAME OF DELINEATOR, DATE OF DRAWING

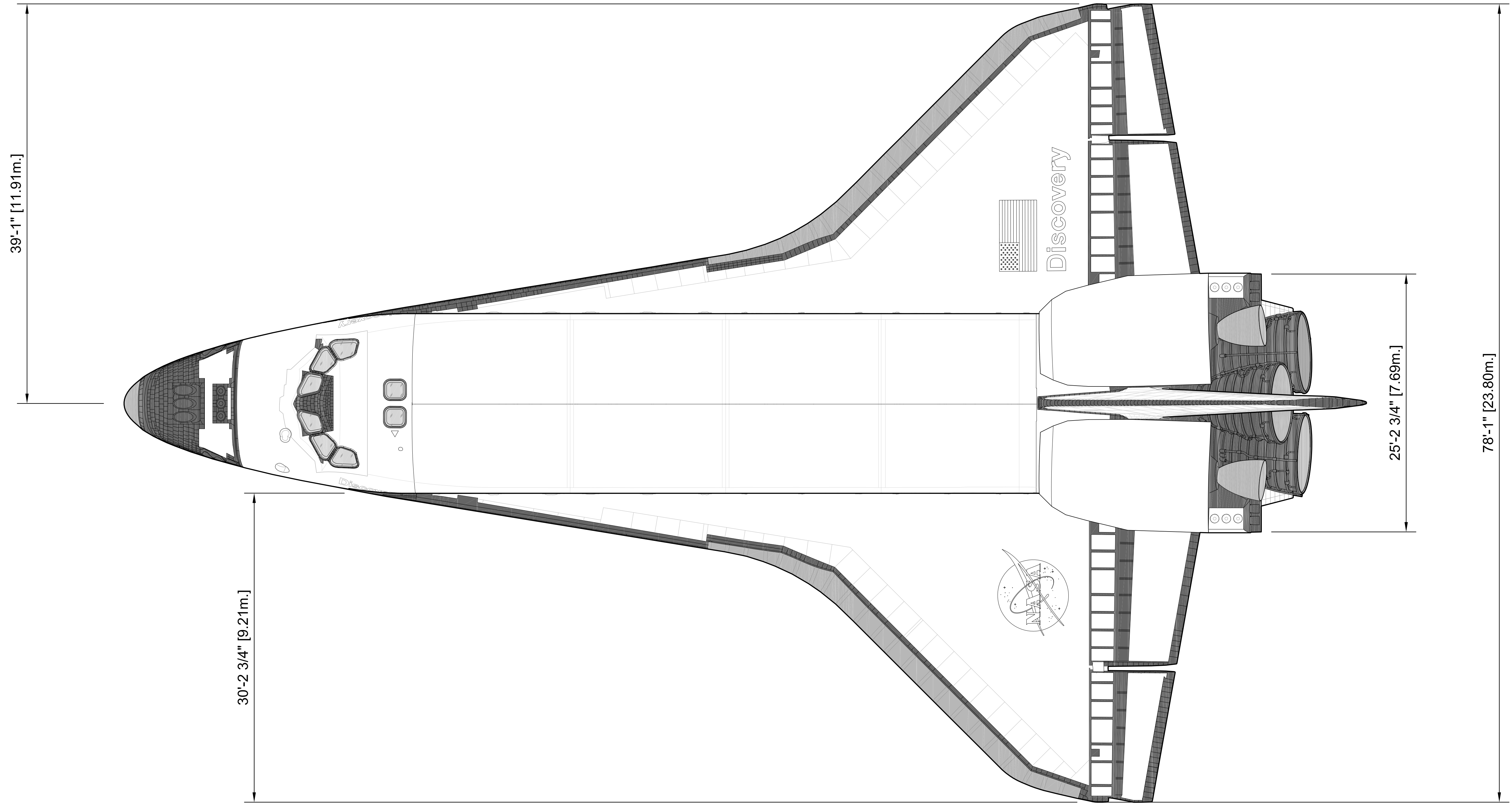

**TOP PLAN**

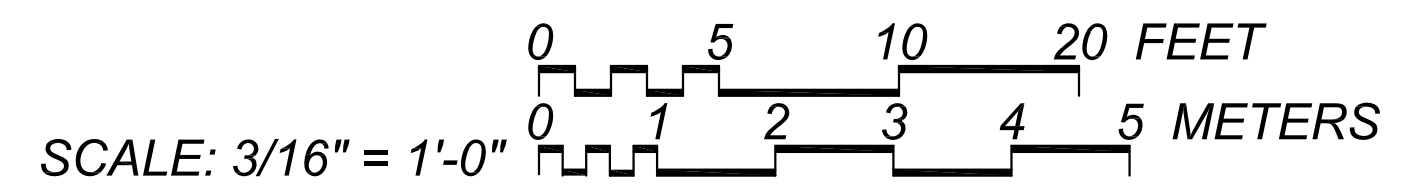

DELINEATED BY: JOHN WACHTEL, JOSEPH KLIMEK

SPACE TRANSPORTATION SYSTEM  
 RECORD DRAWING SERVICE  
 NATIONAL PARK SERVICE  
 UNITED STATES DEPARTMENT OF THE INTERIOR

HOUSTON

SPACE TRANSPORTATION SYSTEM, ORBITER DISCOVERY (OV-103)

JOHNSON SPACE CENTER, 2101 NASA PARKWAY  
 HARRIS COUNTY

TEXAS

SHEET 07 OF 15

HISTORIC AMERICAN  
 ENGINEERING RECORD

TX-116-A

INDEX NUMBER

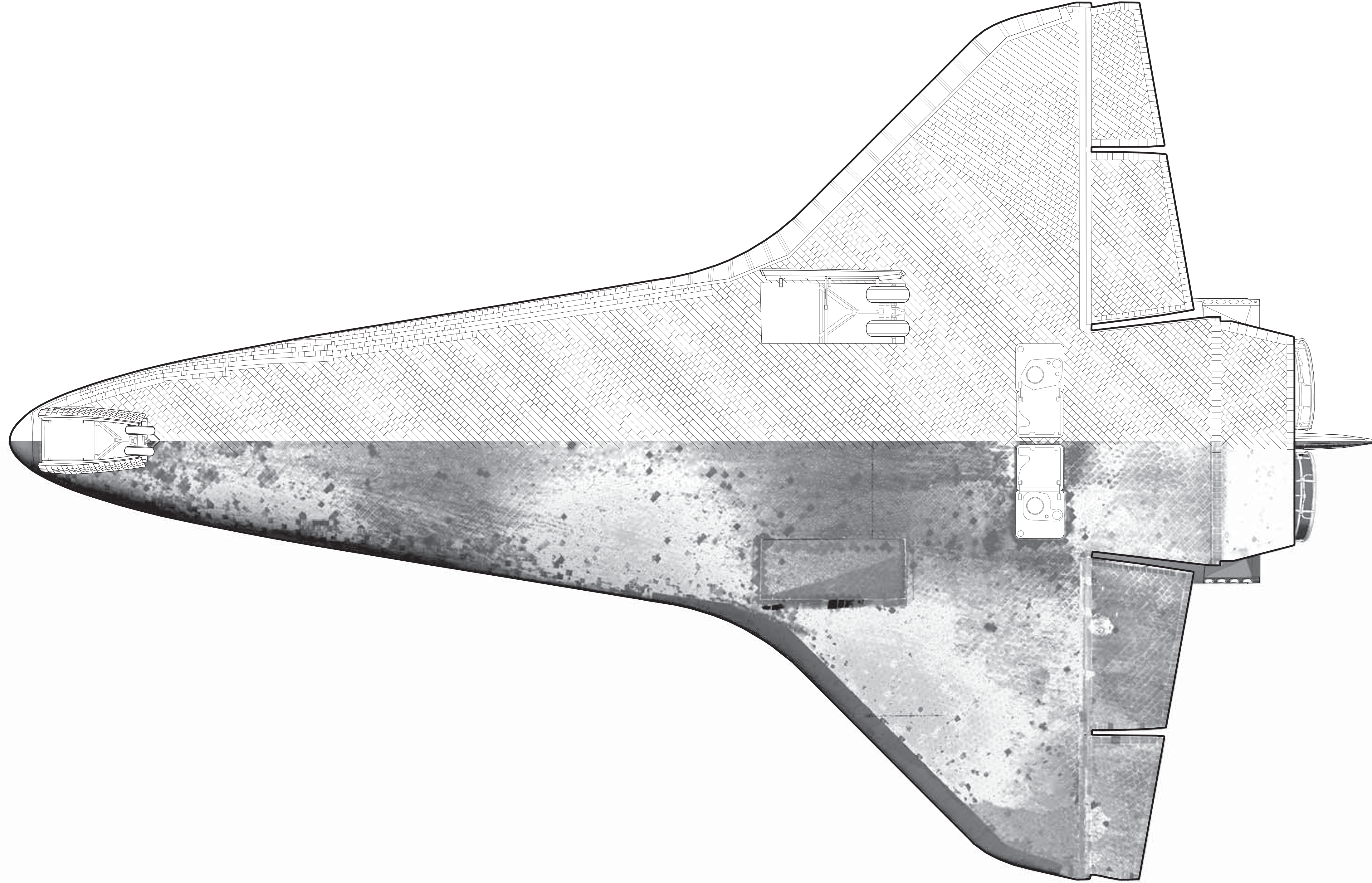

\*THE LOWER HALF OF THIS DRAWING SHOWS TILE INFORMATION GATHERED BY THE HIGH DEFINITION LASER SCANNER. THE CONTRAST HAS BEEN MODIFIED TO BETTER ILLUSTRATE THE WEAR OVER TIME.

# BOTTOM PLAN

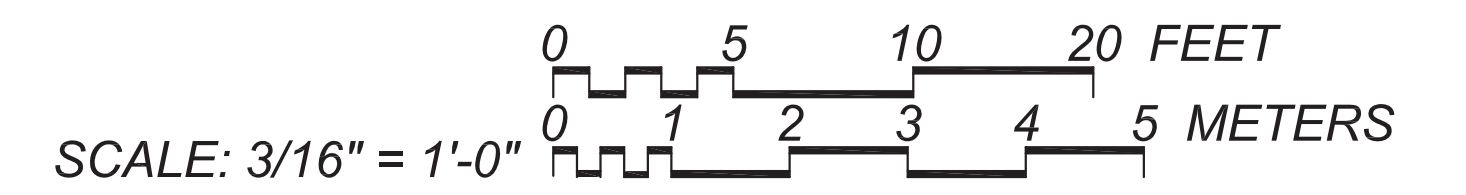

DELINEATED BY: JOHN WACHTEL, JOSEPH KLIMEK  
SPACE TRANSPORTATION SYSTEM  
RECORDING PROJECT  
NATIONAL PARK SERVICE  
UNITED STATES DEPARTMENT OF THE INTERIOR

HOUSTON

SPACE TRANSPORTATION SYSTEM ORBITER DISCOVERY (OV-103)  
JOHNSON SPACE CENTER, 2101 NASA PARKWAY  
HARRIS COUNTY

TEXAS

SHEET 08 OF 15

HISTORIC AMERICAN  
ENGINEERING RECORD  
TX-116-A

LIBRARY OF CONGRESS  
INDEX NUMBER

# REPRODUCED PLEASE CREDIT THE HISTORIC AMERICAN ENGINEERING RECORD, NATIONAL PARK SERVICE, NAME OF DELINEATOR, DATE OF DRAWING

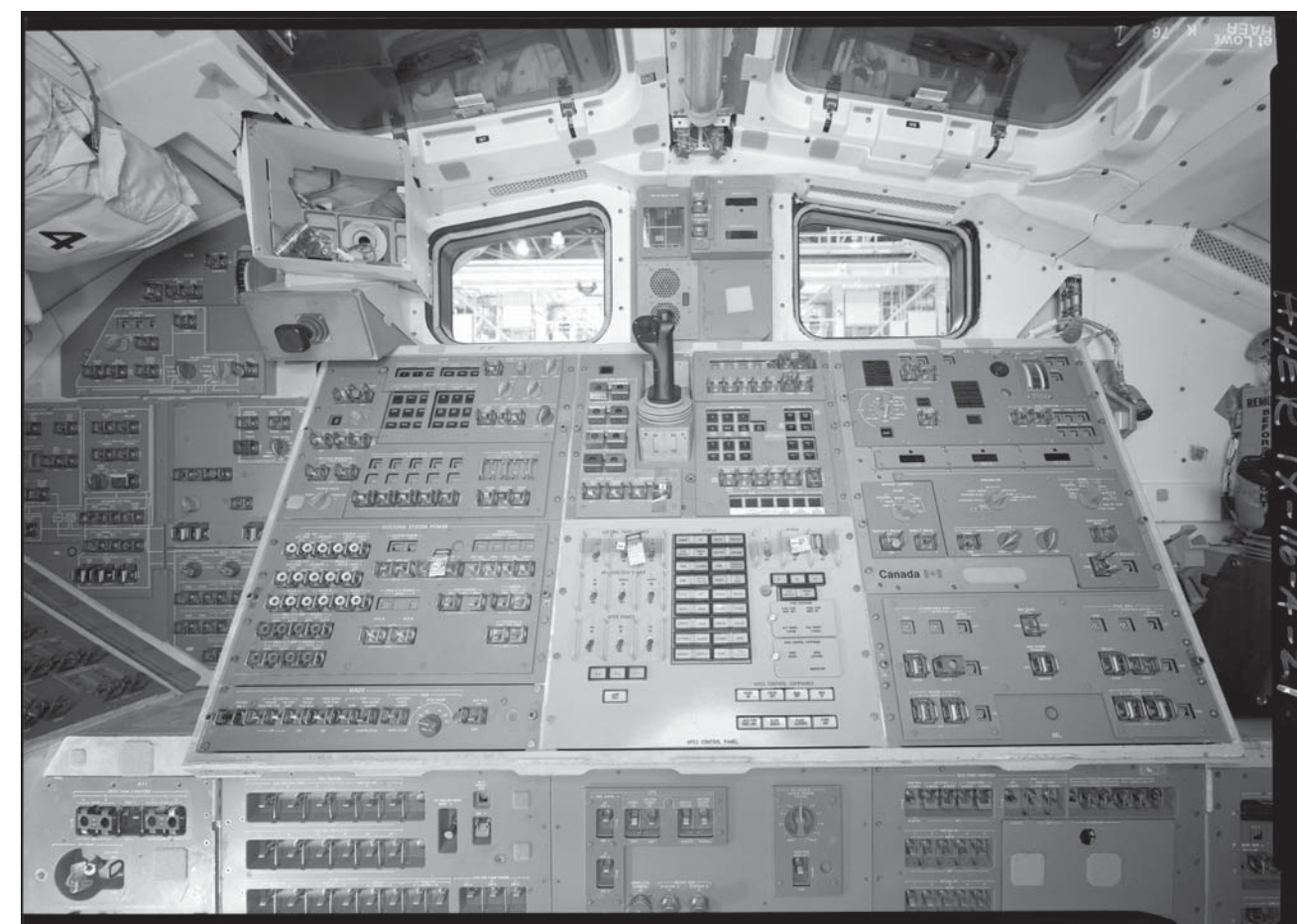
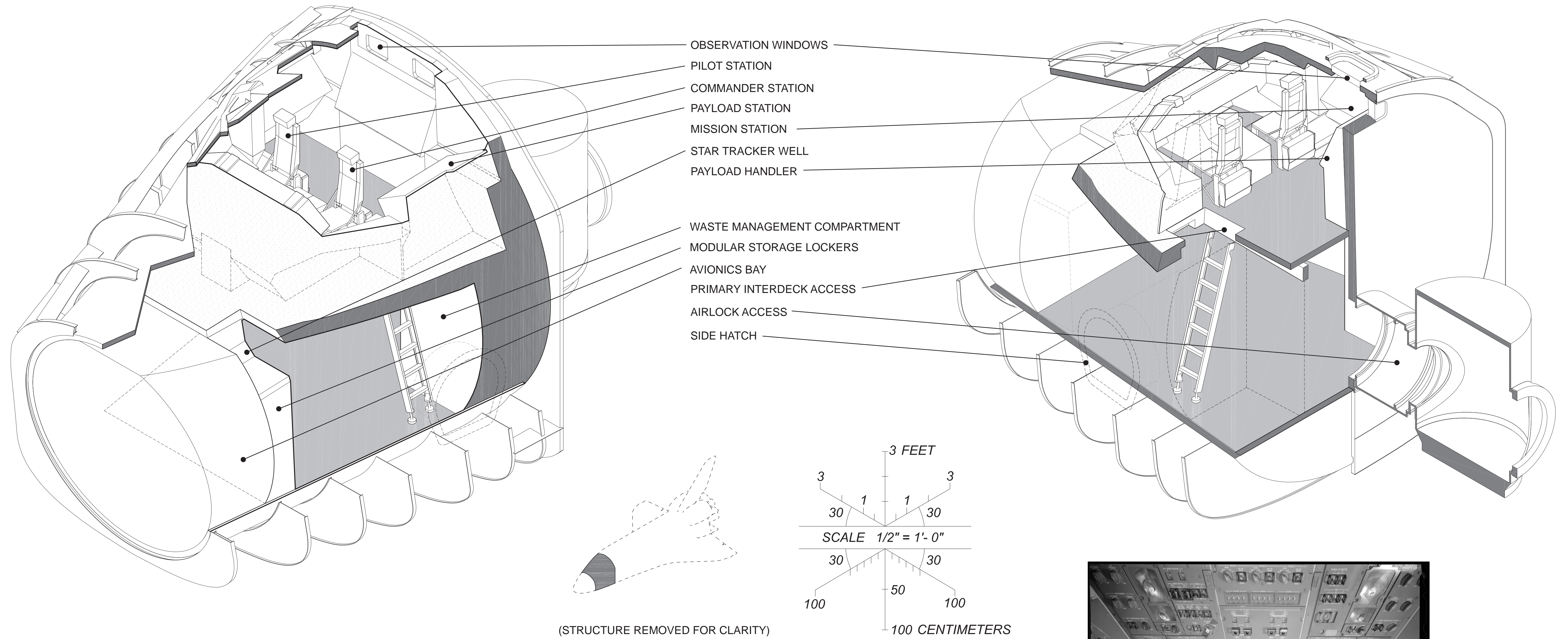

The aft station has two overhead and aft viewing windows for viewing and orbital operations. The aft flight deck station also contains displays and controls for the Reaction Control System, the Orbiter Docking System, Payload Deployment and Retrieval System, including the Remote Manipulator System, Payload Bay Door operations and closed circuit television operations.

Directly beneath the flight deck is the middeck. Access to the middeck is through two inter-deck openings, which measure 26x28 inches. Normally the right inter-deck opening is closed and the left is open. A ladder attached to the left inter-deck access allows passage in 1-G conditions and the Orbiter in horizontal position. The middeck provides the crew's sleep, work and living accommodations and contains three avionics equipment bays. Attached to the aft bay on the port side of the vehicle is the waste management compartment and closeouts which create a stowage compartment known as volume 3B. Just forward of the waste management system is the side hatch. The completely stripped middeck is approximately 160 square feet; the gross mobility area is approximately 100 square feet.

## CREW CABIN ISOMETRIC

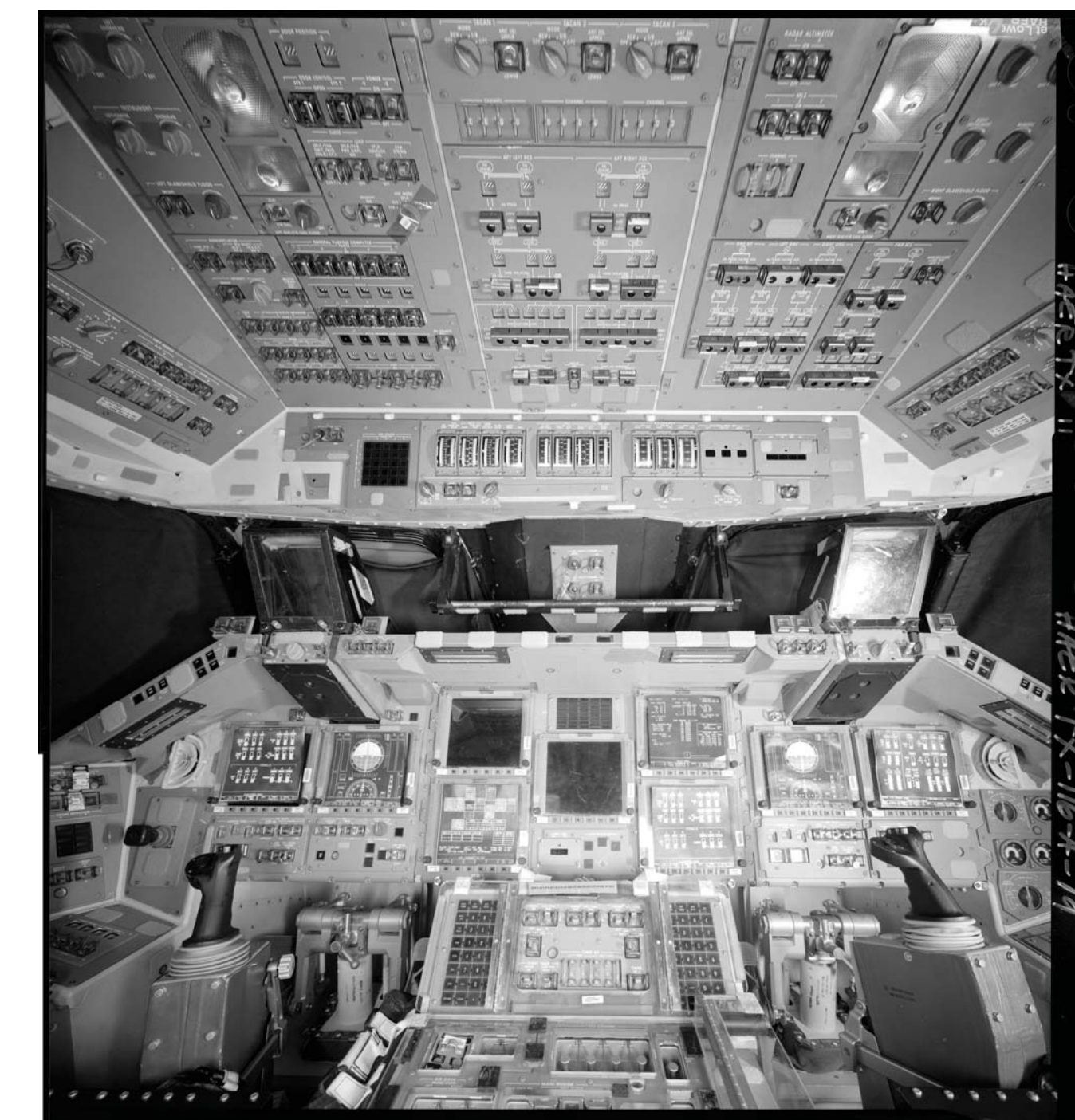

The flight deck is the uppermost compartment of the crew cabin and contained the Orbiter cockpit and aft station. The commander's and pilot's seats and work stations are positioned side by side in the cockpit section of the flight deck. These stations have controls and displays for controlling the vehicle throughout all mission phases in addition to six windows to observe orbit operations. Directly behind and to the sides of the commander and pilot centerline are the mission specialist seats and stations.

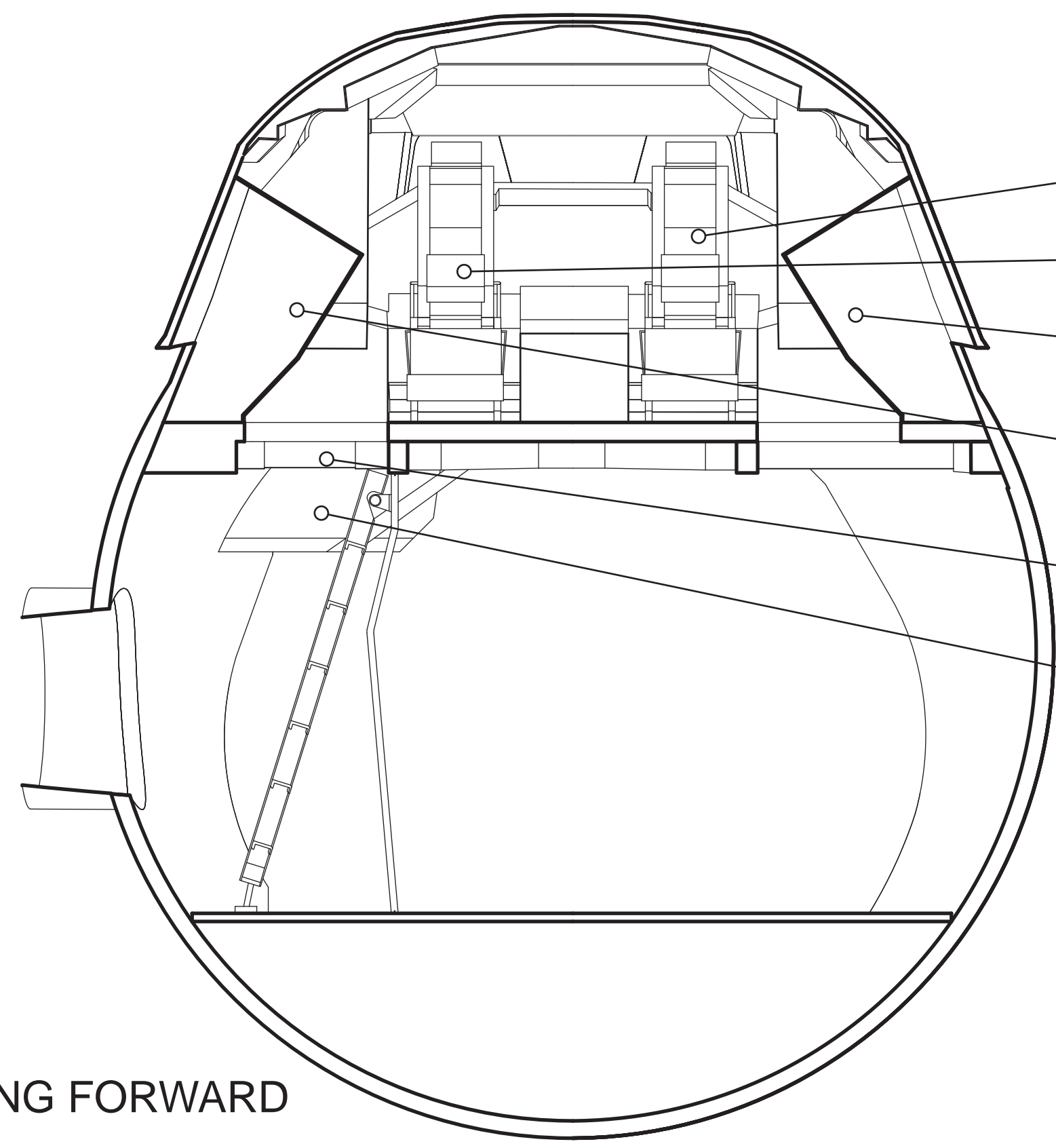

LOOKING FORWARD

- PILOT STATION
- COMMANDER STATION
- MISSION STATION
- PAYLOAD STATION
- PRIMARY INTERDECK ACCESS
- STAR TRACKER WELL

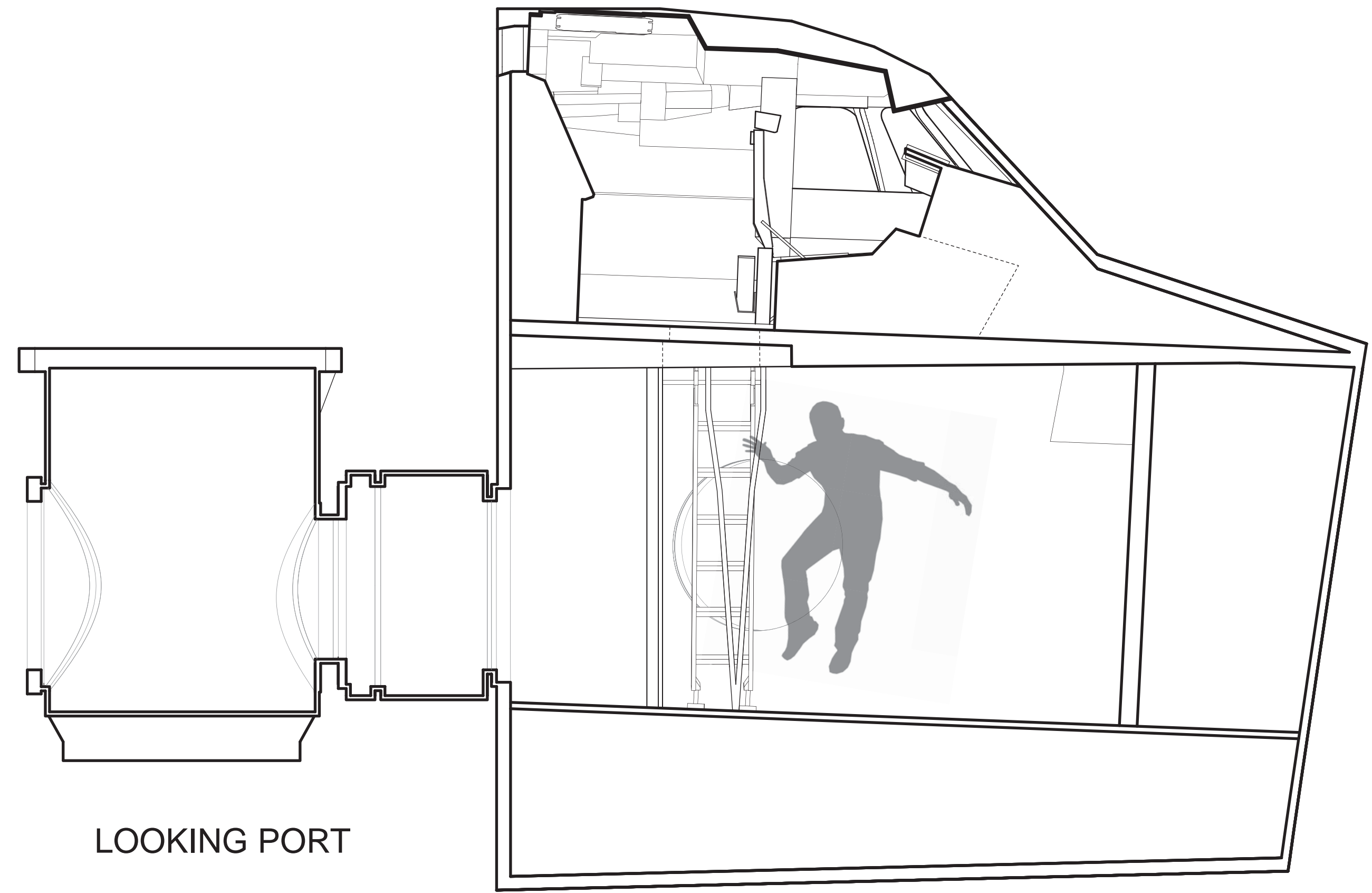

LOOKING PORT

SCALE: 1/2" = 1'-0"

0 1 2 3 4 5 FEET  
0 50 100 150 CENTIMETERS

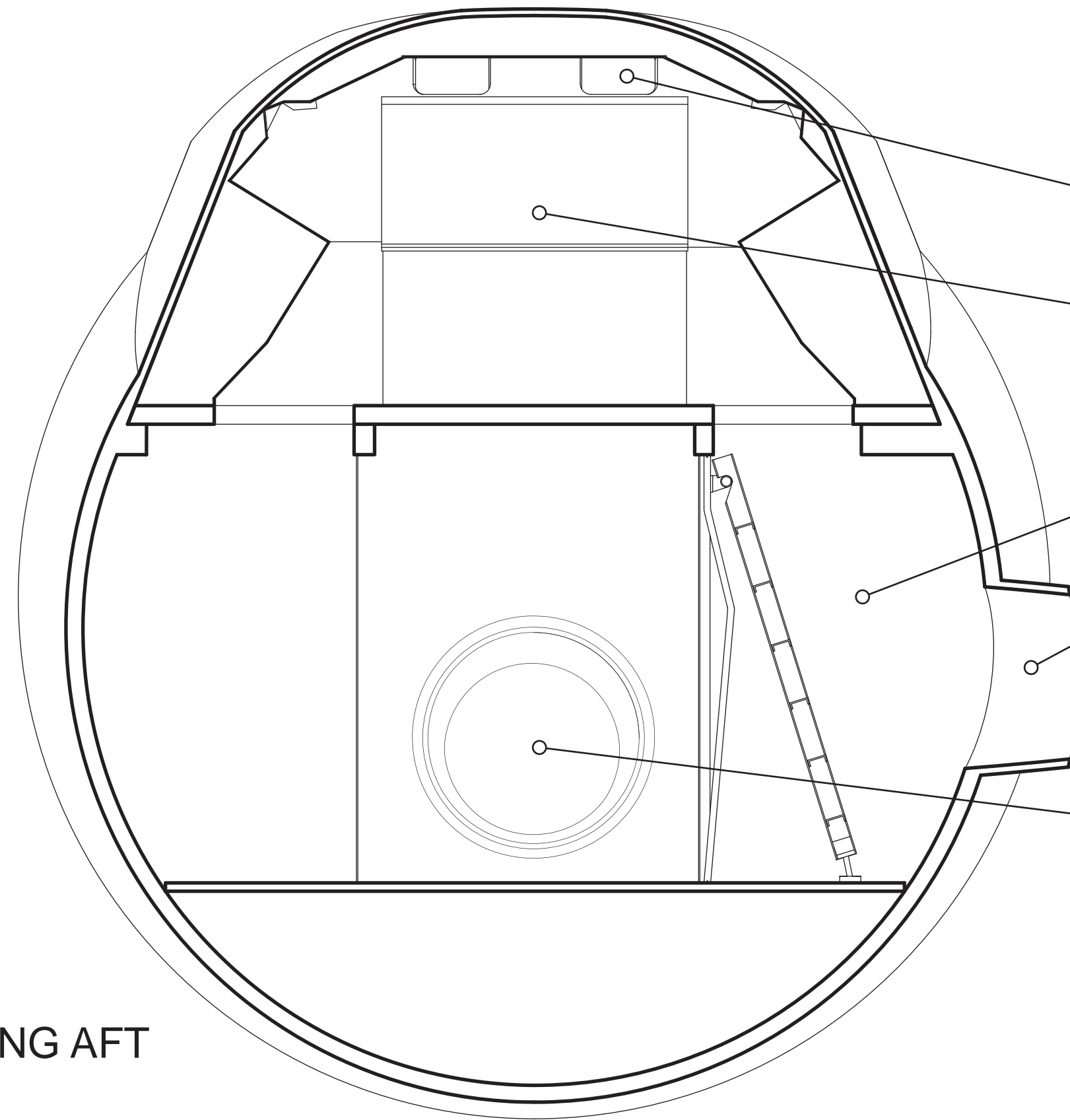

LOOKING AFT

- OBSERVATION WINDOWS
- PAYLOAD HANDLER
- WASTE MANAGEMENT COMPARTMENT
- SIDE HATCH
- MODULAR STORAGE LOCKERS
- AVIONICS BAY
- AIRLOCK ACCESS

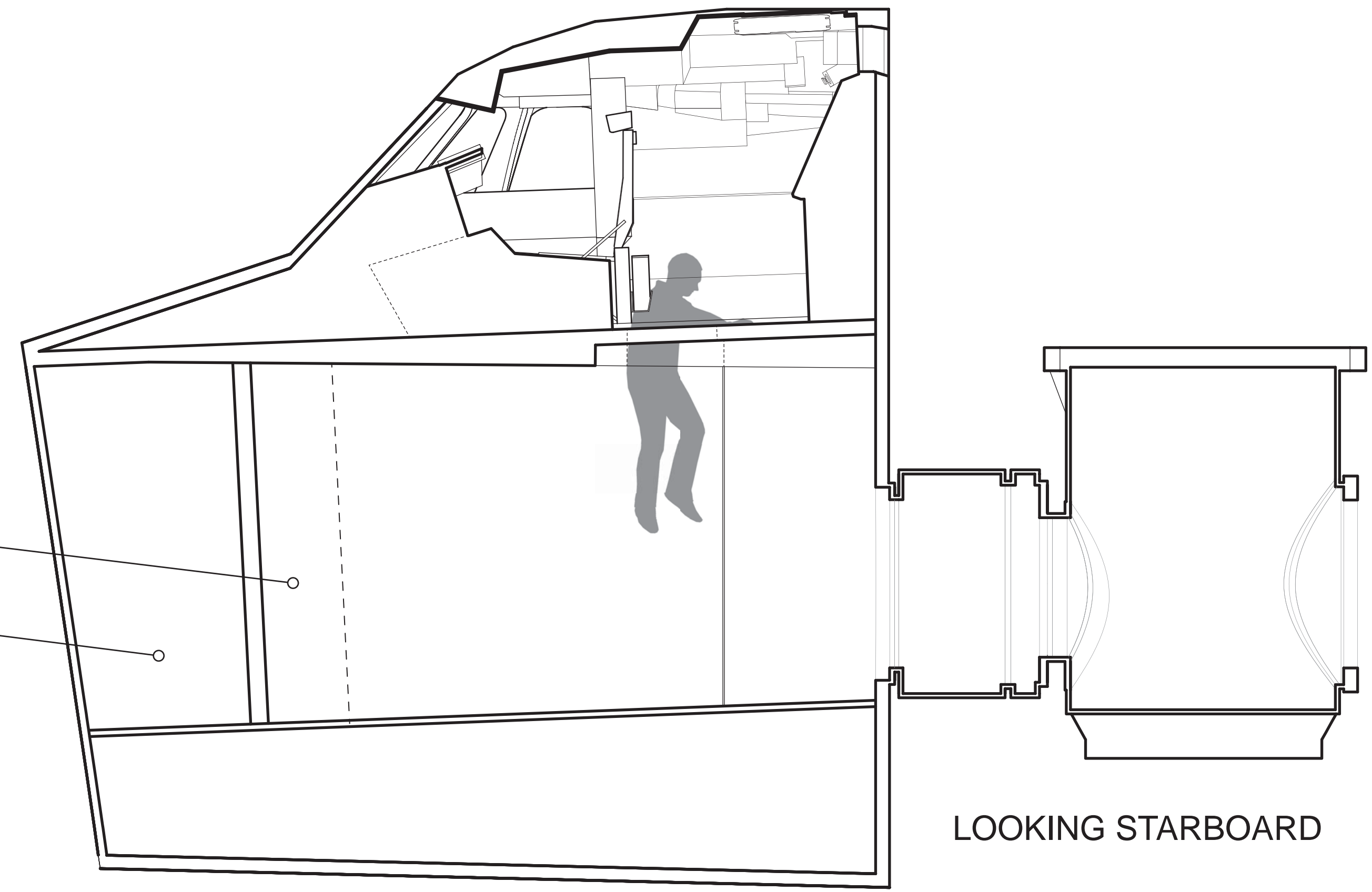

LOOKING STARBOARD

# CREW CABIN SECTIONS

RELEASED - Printed documents may be obsolete; validate prior to use.

- (A) MANIPULATOR POSITIONING MECHANISM PEDESTALS
- (B) BRIDGE FITTING/RETENTION MECHANISMS
- (C) PAYLOAD DOOR AND RADIATOR PANELS
- (D) ELECTRICAL WIRE TRAY
- (E) OBSS
- (F) RMS

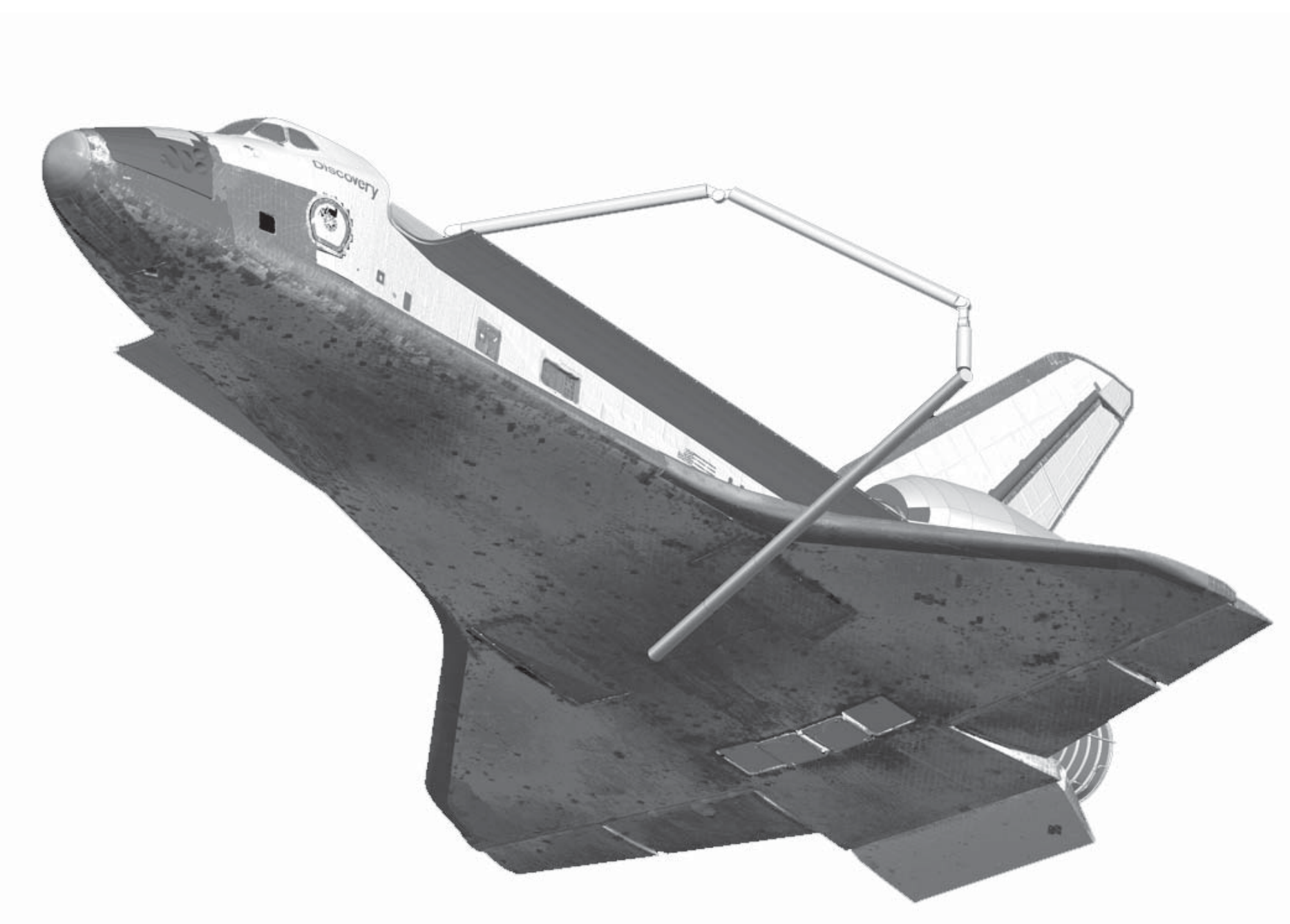
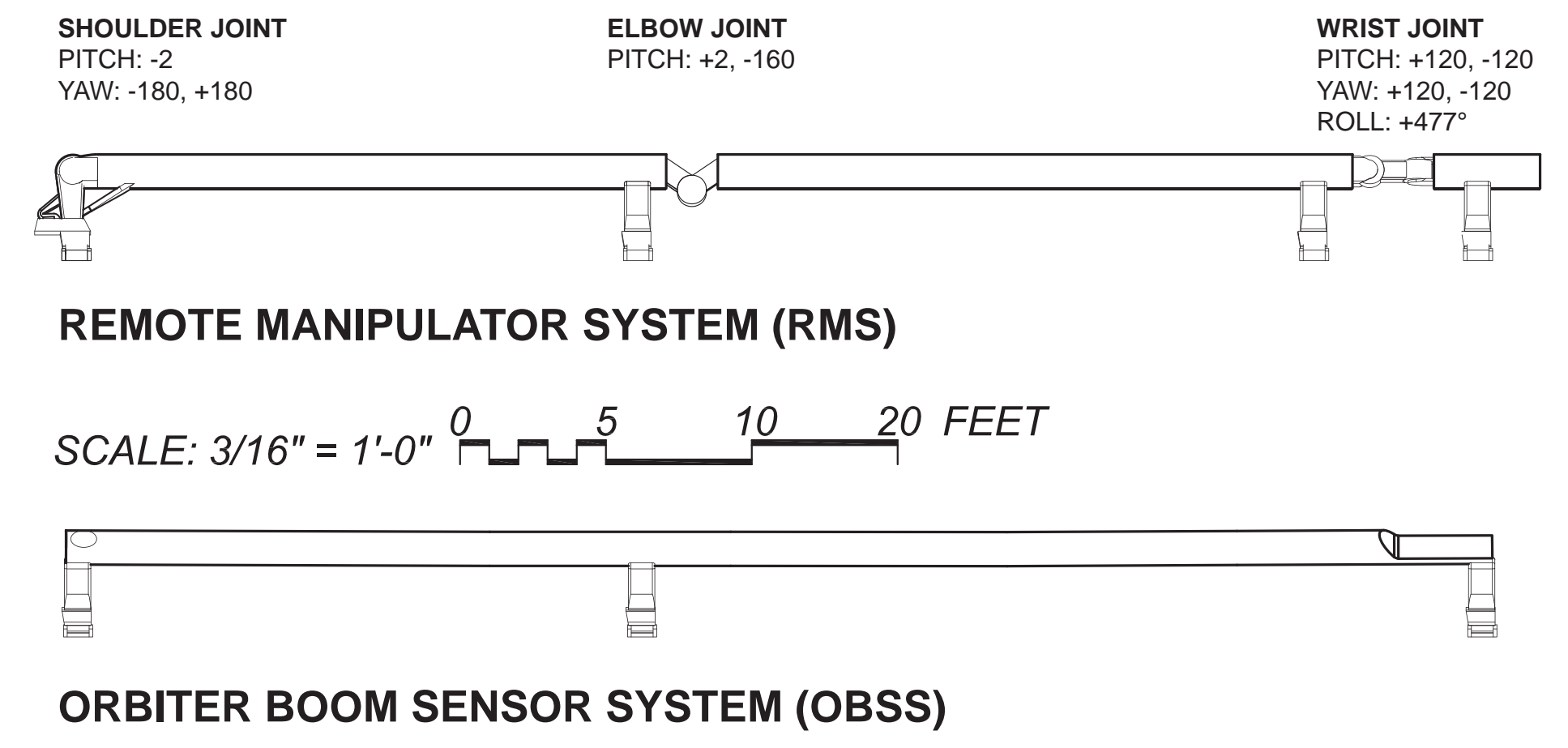
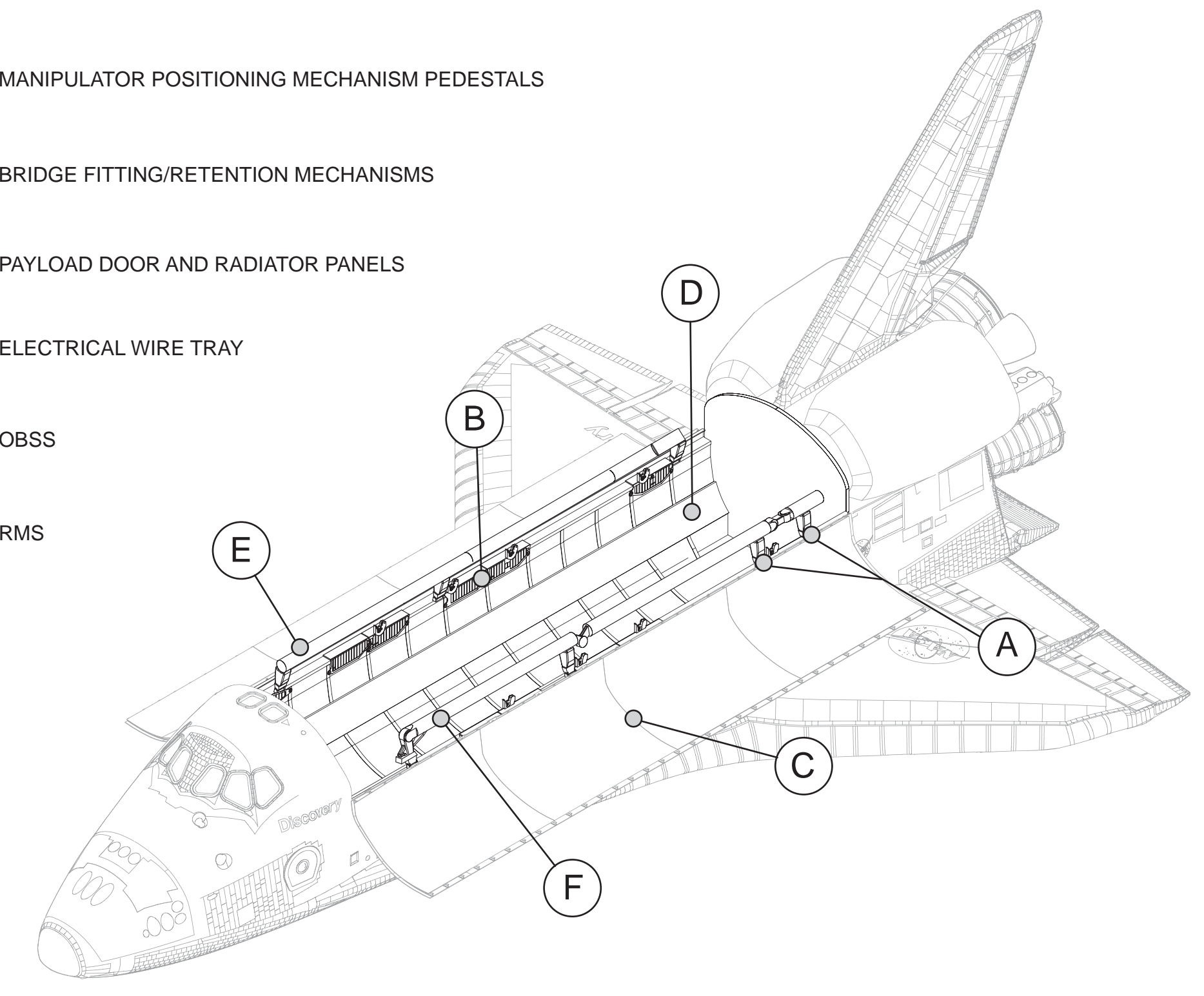

Non-deployable payloads were retained by bolted passive retention devices, and deployable payloads were secured by motor driven active retention devices. Payloads were secured in the orbiter payload bay with the payload retention system or were equipped with their own unique retention systems. Attachment points in the payload bay were in 3.933 inch increments along the left and right side longerons and along the bottom centerline. Of the potential 172 attach points on the longerons, 48 were unavailable because of their proximity to spacecraft hardware.

Bridge fittings were used to react to the load imparted to the orbiter structure by the payload, and provided a structural interface for both the payload retention s latch assemblies (PRLA) and active keel actuators (AKA).

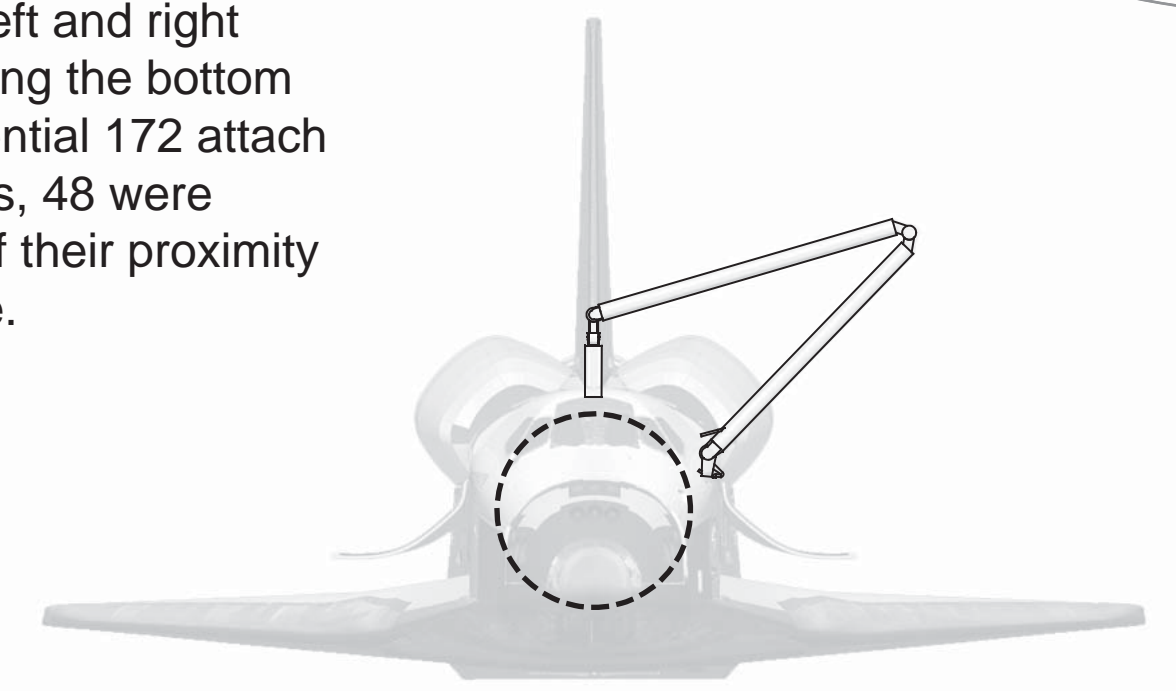

PAYLOAD RETRIEVAL USING THE RMS

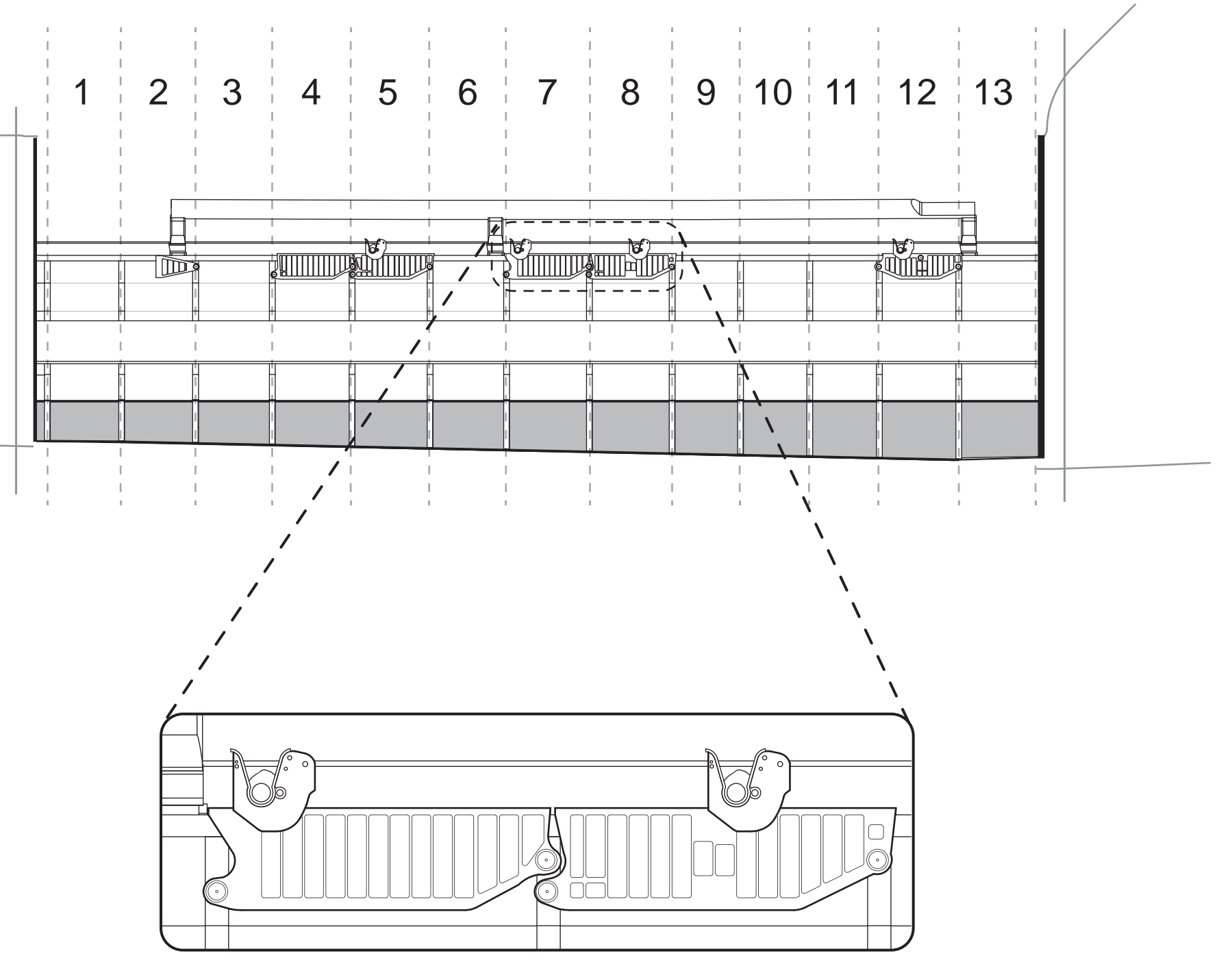

BRIDGE FITTINGS AND RETENTION MECHANISMS

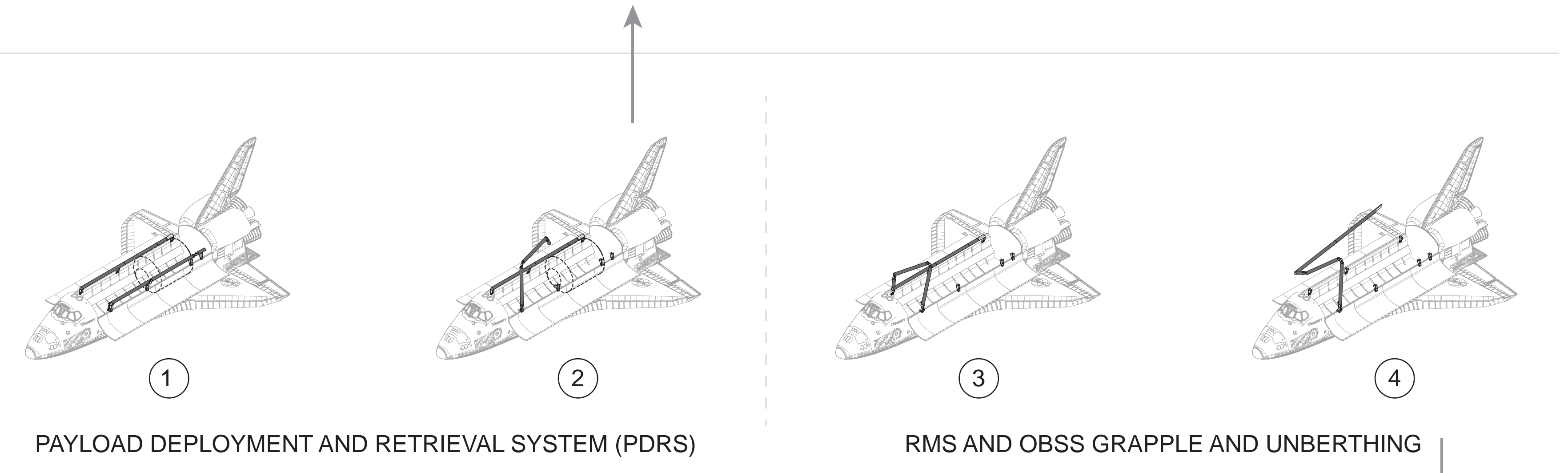

The payload deployment and retrieval system (PDRS) consisted of the hardware, software, and interfaces required to remotely hold and control the movements of a specified object, usually a payload, and to remotely observe or monitor objects or activities.

The Remote Manipulator System (RMS) was installed on the port sill-longeron of the orbiter payload bay for those missions which required it. The RMS was capable of deploying or retrieving payloads weighing up to 65,000 pounds. The RMS could also retrieve and deploy satellites, provide a mobile extension for extravehicular activity (EVA), and be used as an inspection aid along with the orbiter boom sensor system which allowed the crew to view the orbiter or payload's surfaces through television cameras.

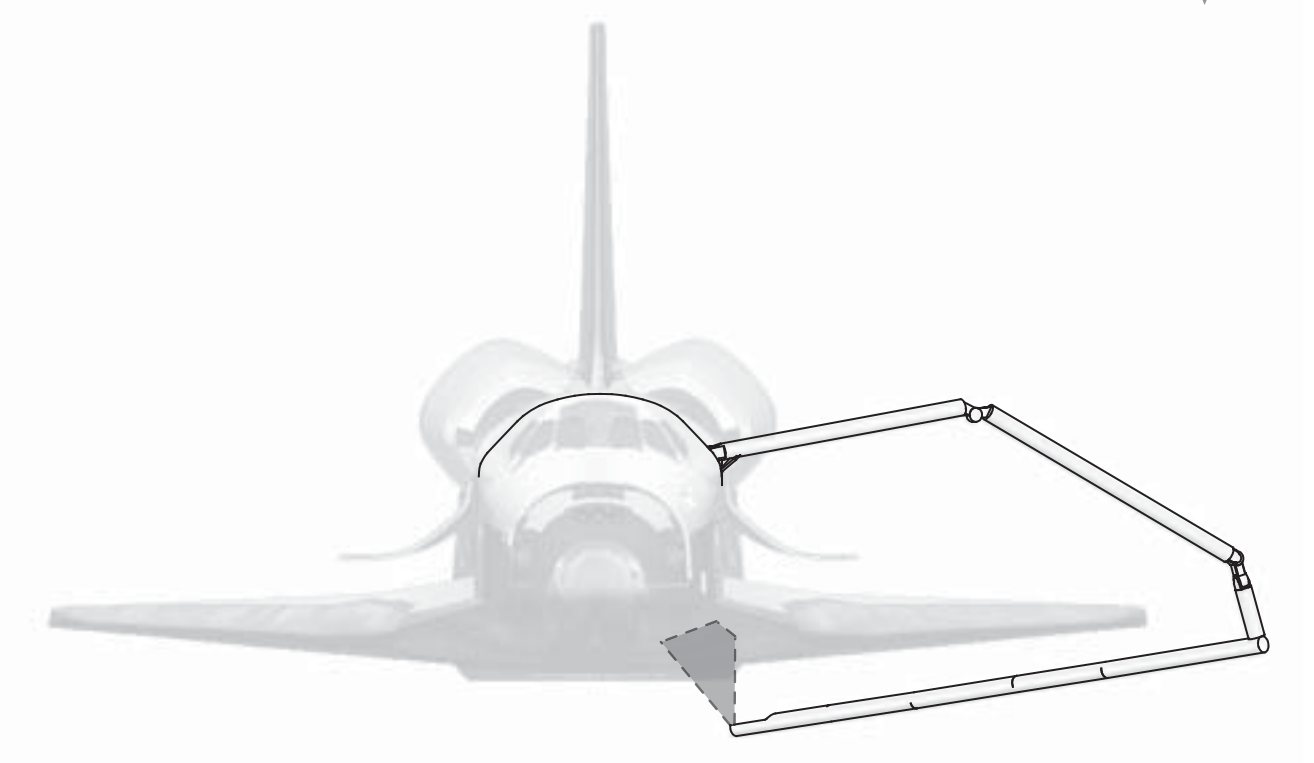

POST ASCENT/PRE ENTRY INSPECTION

# PAYLOAD BAY AND PDRS

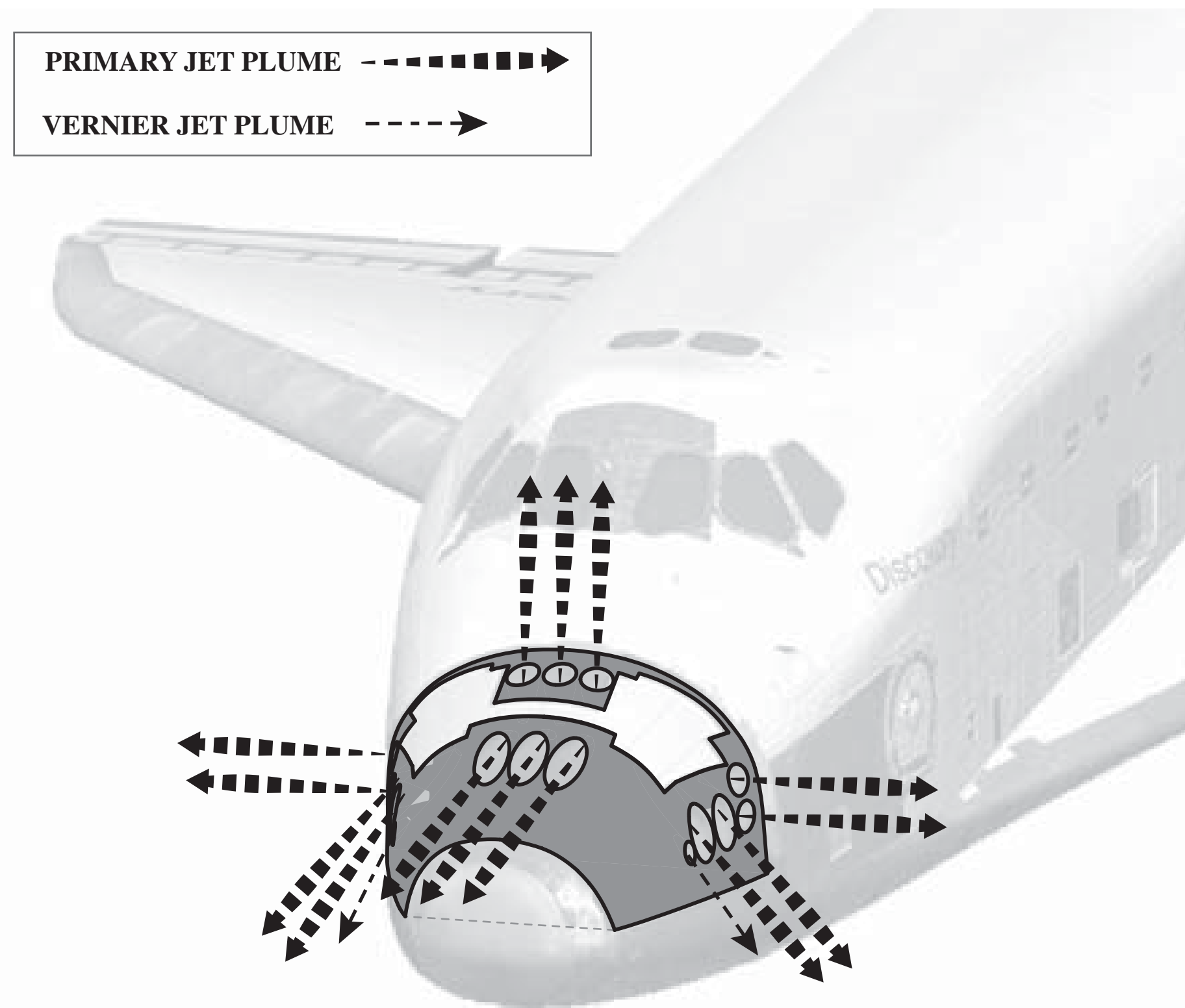

**FORWARD REACTION CONTROL SYSTEM (RCS)**

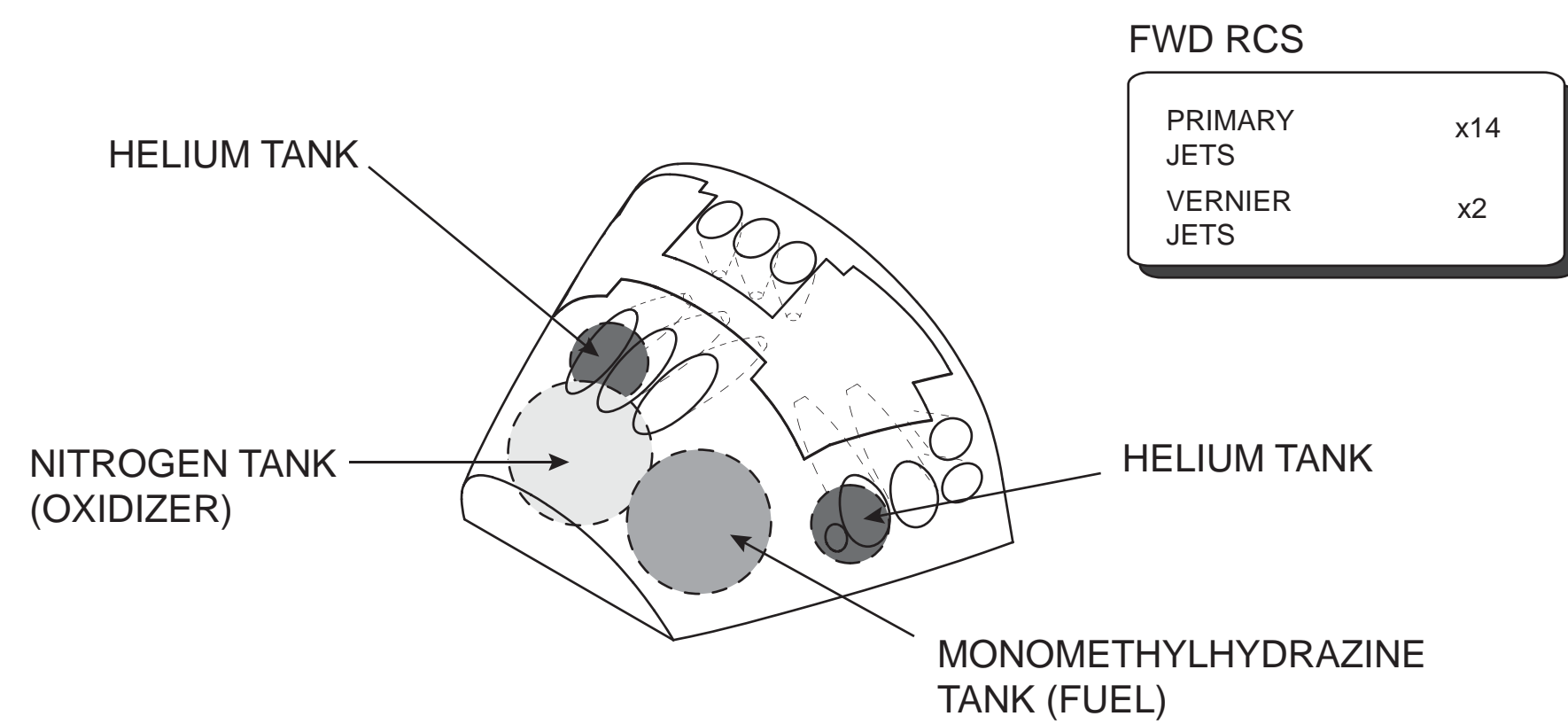

The orbiter's RCS consisted of forward and aft control jets, propellant storage tanks, and distribution networks located in three vehicle modules: forward, left, and right. The forward module was contained in the nose area, forward of the cockpit windows. The left and right (aft) modules were located with the Orbital Maneuvering System (OMS) in the left and right OMS/RCS pods located on the sides of the vertical stabilizer. Each RCS consisted of high pressure gaseous helium storage tanks, pressure regulation and relief systems, a fuel and oxidizer tank, a propellant distribution system, reaction control jets, and electrical jet and pod heaters.

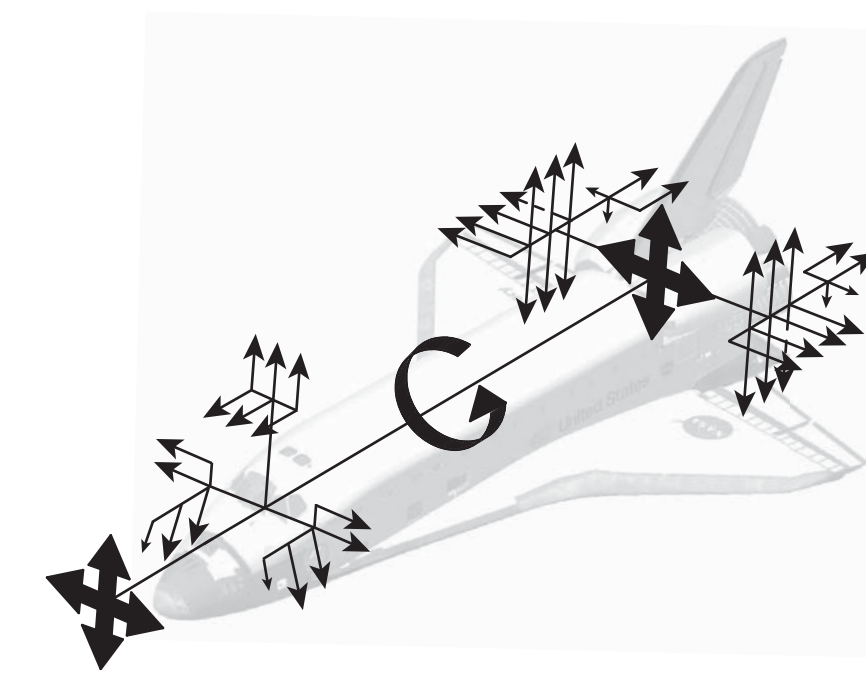

**RCS JET MANEUVERS**

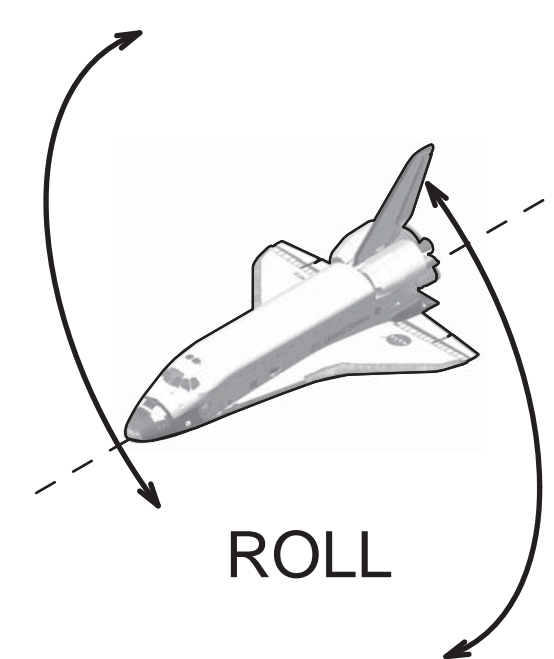
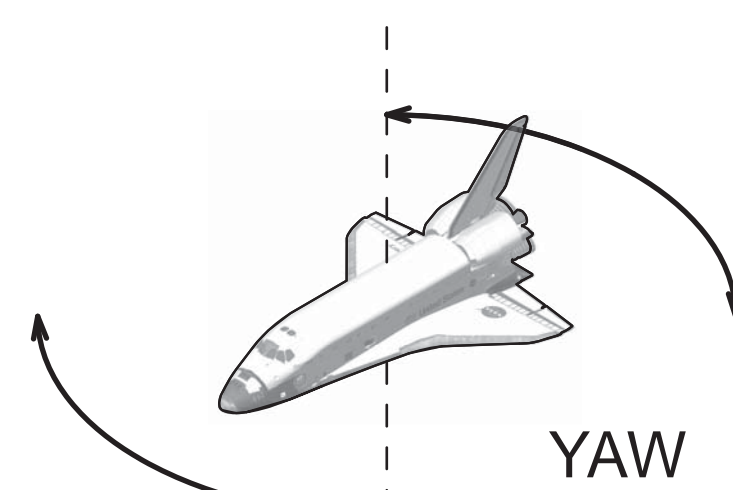
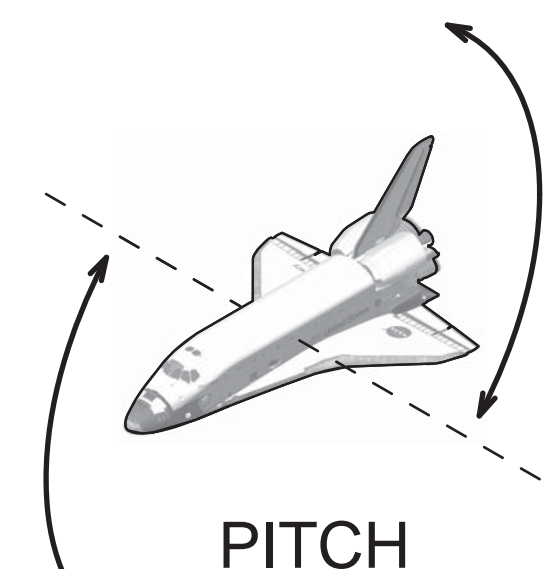
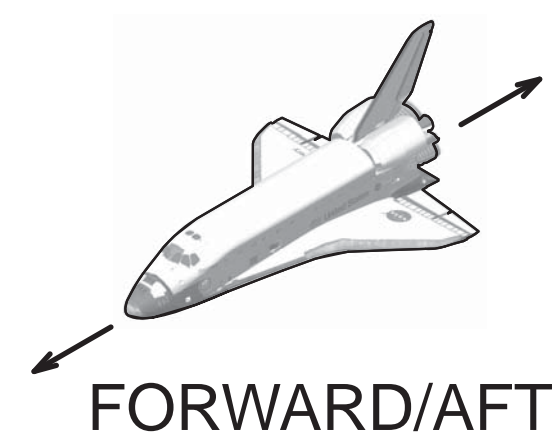

## OMS AND RCS

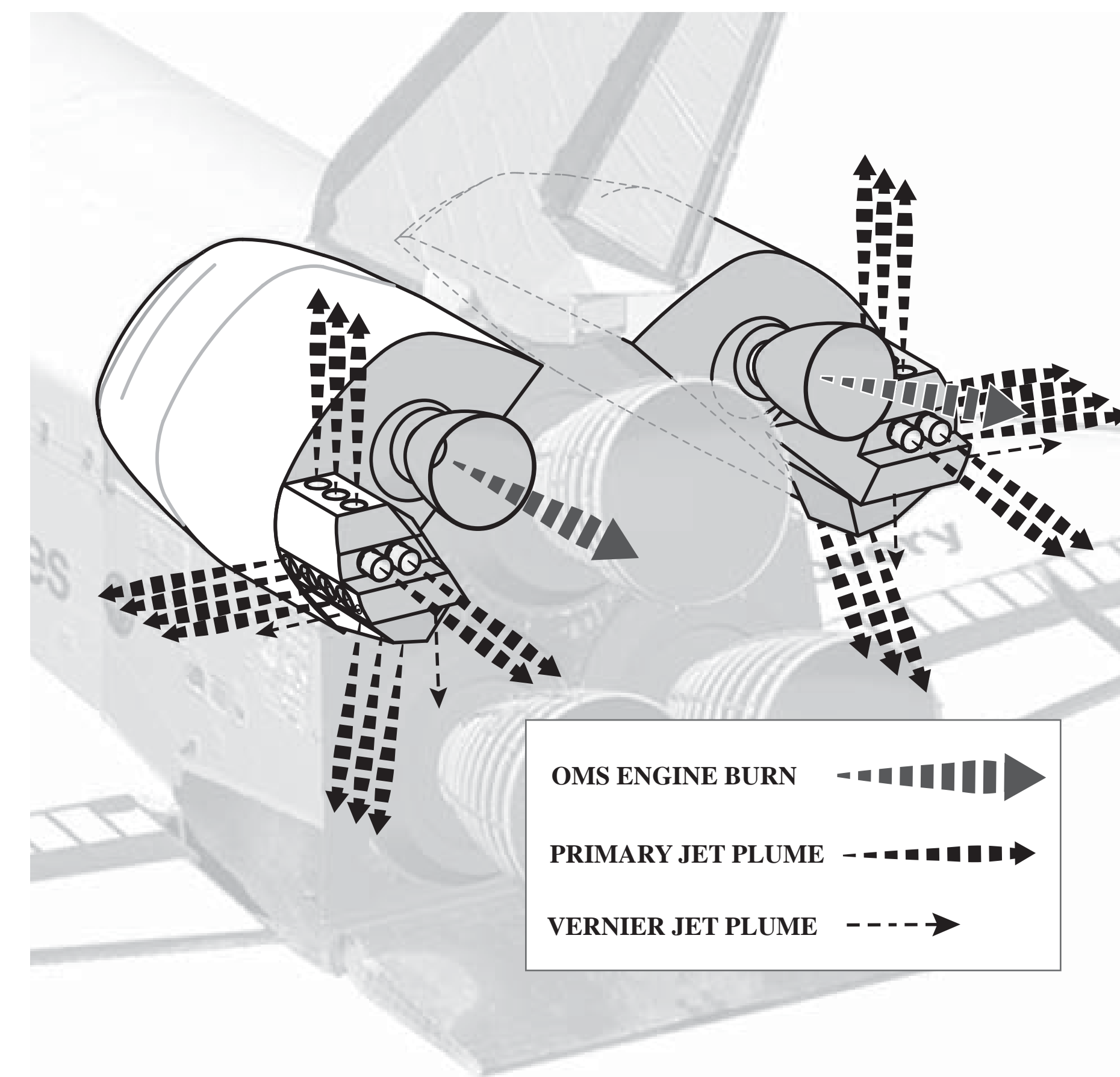

**ORBITAL MANEUVERING SYTEM (OMS)  
&  
AFT REACTION CONTROL SYSTEM (RCS)**

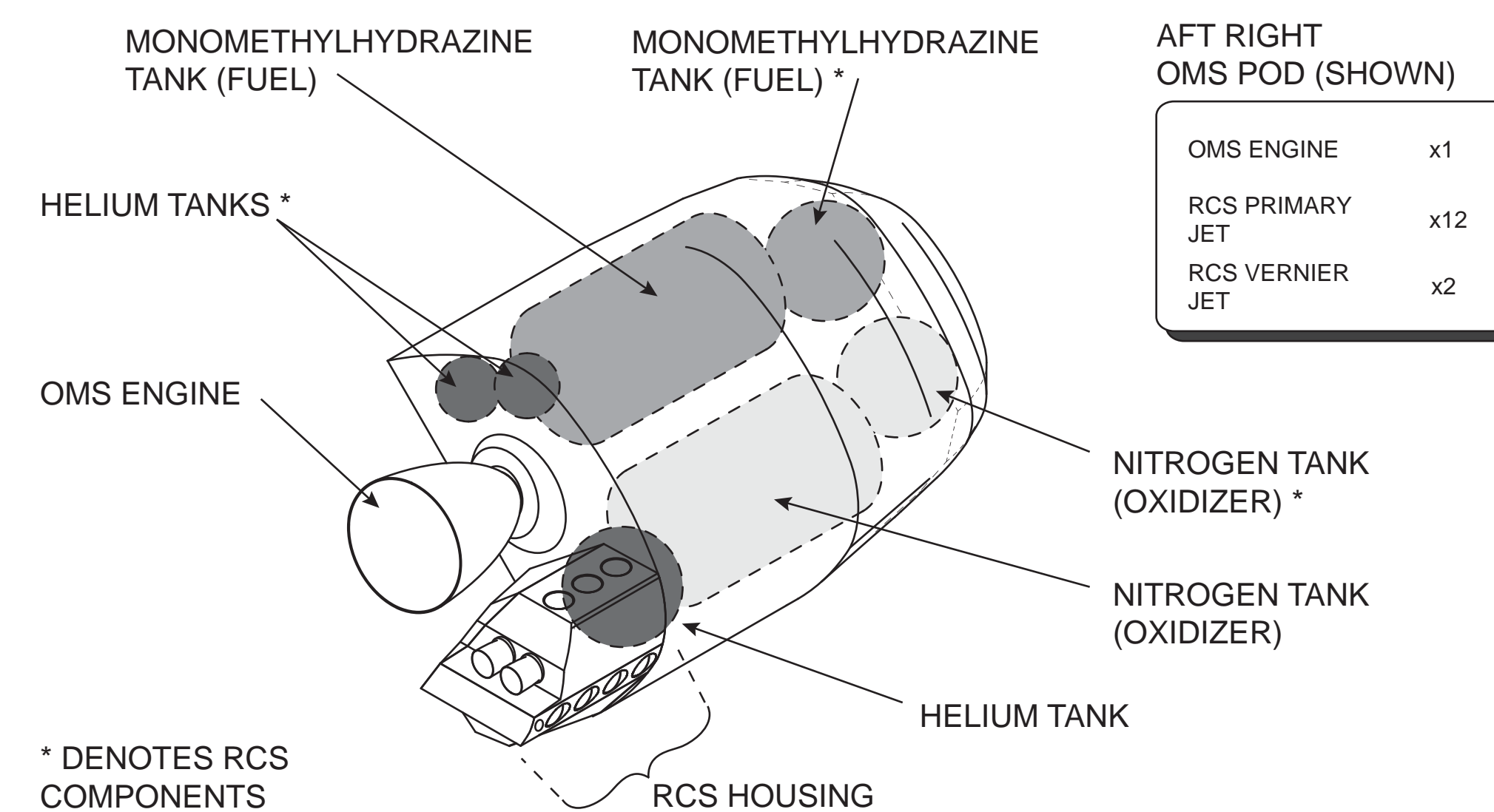

The OMS provided propulsion for the Orbiter during the orbit phase of flight. The OMS is used for orbit insertion, orbit circulation, orbit transfer, rendezvous, and deorbit. Each OMS pod provided more than 1,000 pounds of propellant to the RCS. Amounts available for crossfeed depended on loading and number of OMS starts during the mission.

# ORBITER TPS: THERMAL PROTECTION SYSTEM

The thermal protection system (TPS) was a passive system that consisted of various materials applied externally to the outer aluminum and graphite-epoxy skin of the Orbiter to prevent the skin from exceeding 350° F, primarily during Orbiter reentry.

The TPS materials were designed to be reusable for up to 100 missions with routine refurbishment and maintenance. In addition to being durable and designed to withstand high reentry temperatures these materials could also withstand the extremely cold temperatures, around minus 250° F, they were exposed to in the space environment. Because the TPS was the outermost layer it also established the aerodynamic profile of the Orbiter in addition to acting as the heat sink.

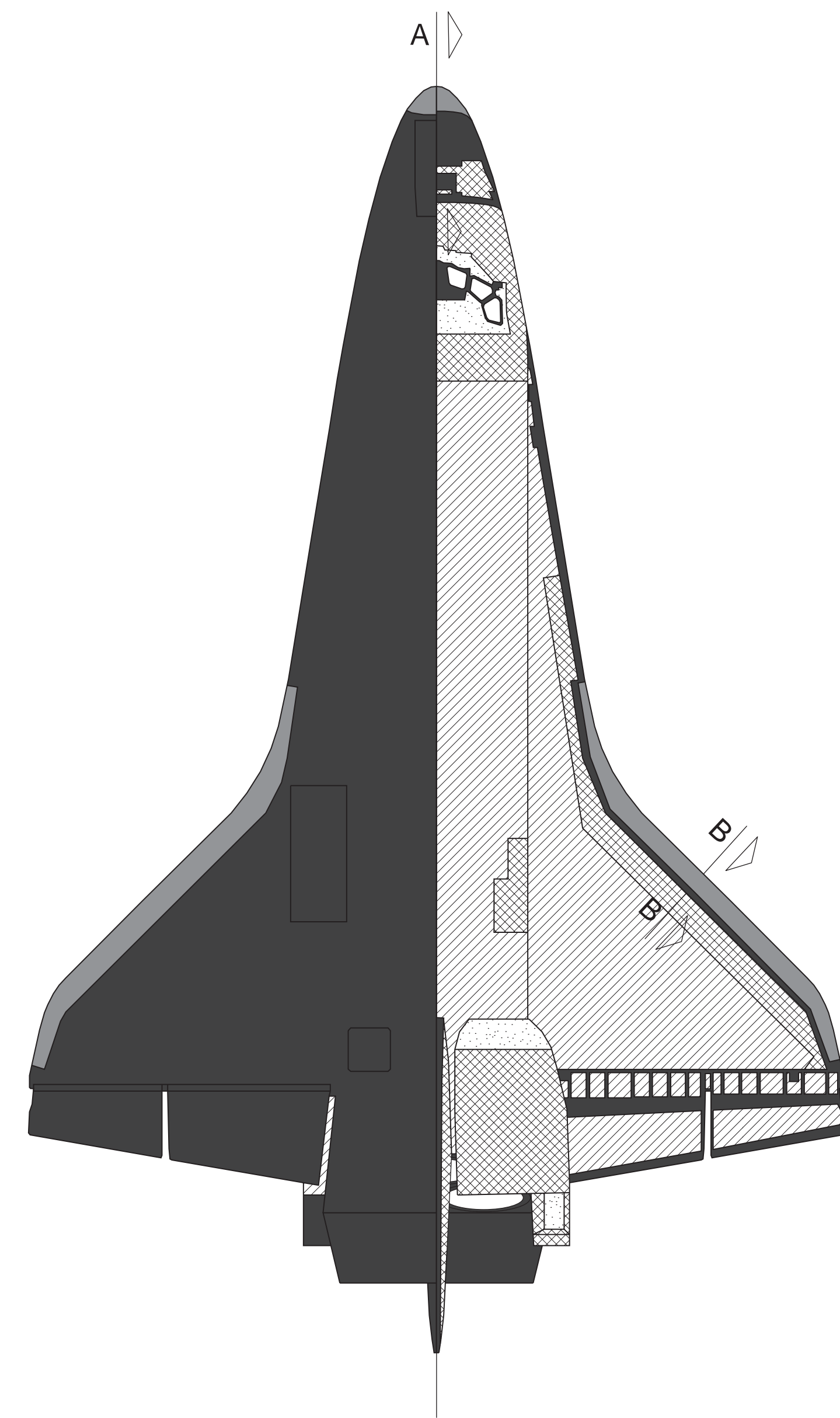

**BOTTOM/ TOP TPS COVER**  
SCALE: 3/32" = 1'-0"

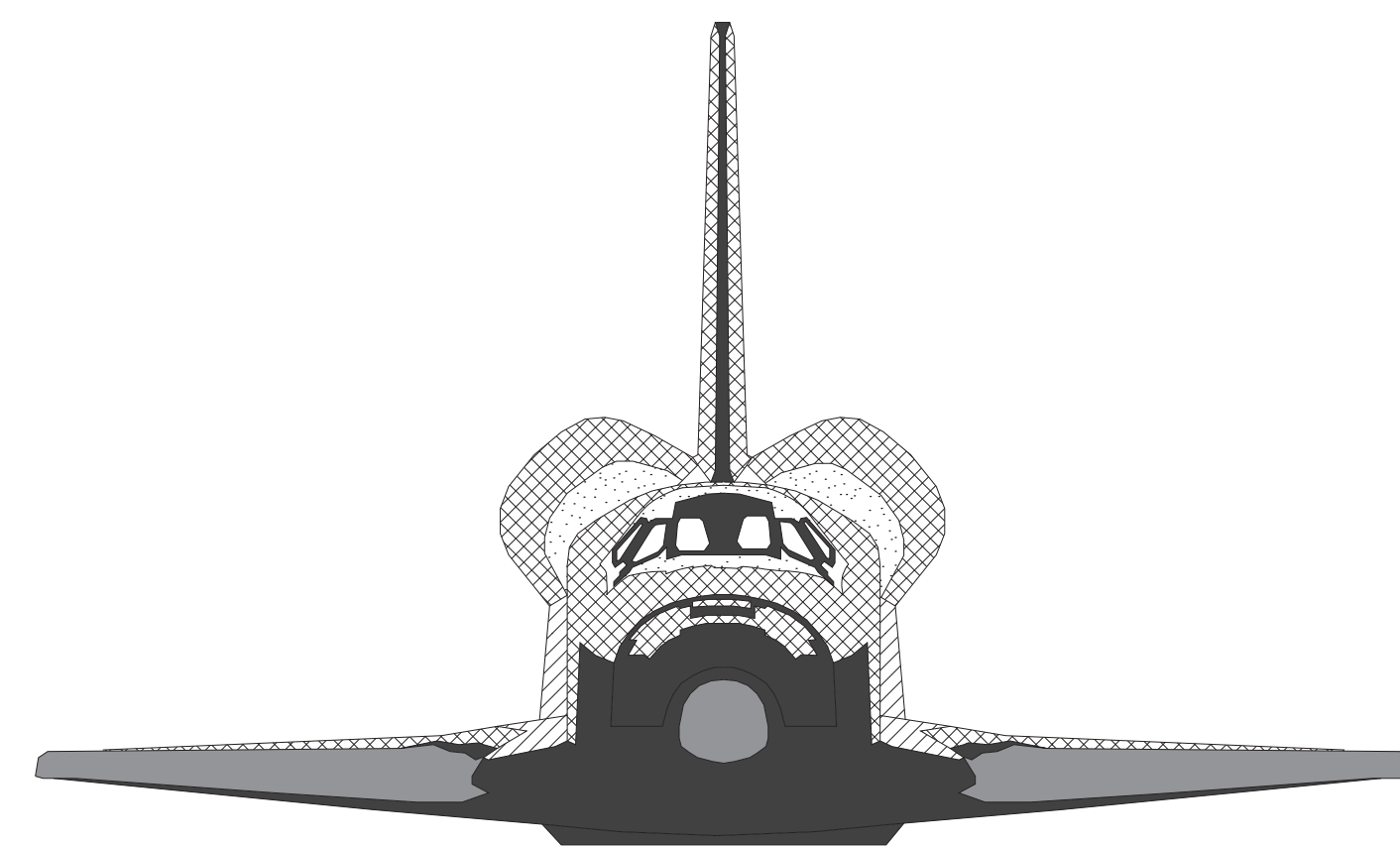

**FRONT TPS COVER**  
SCALE: 3/32" = 1'-0"

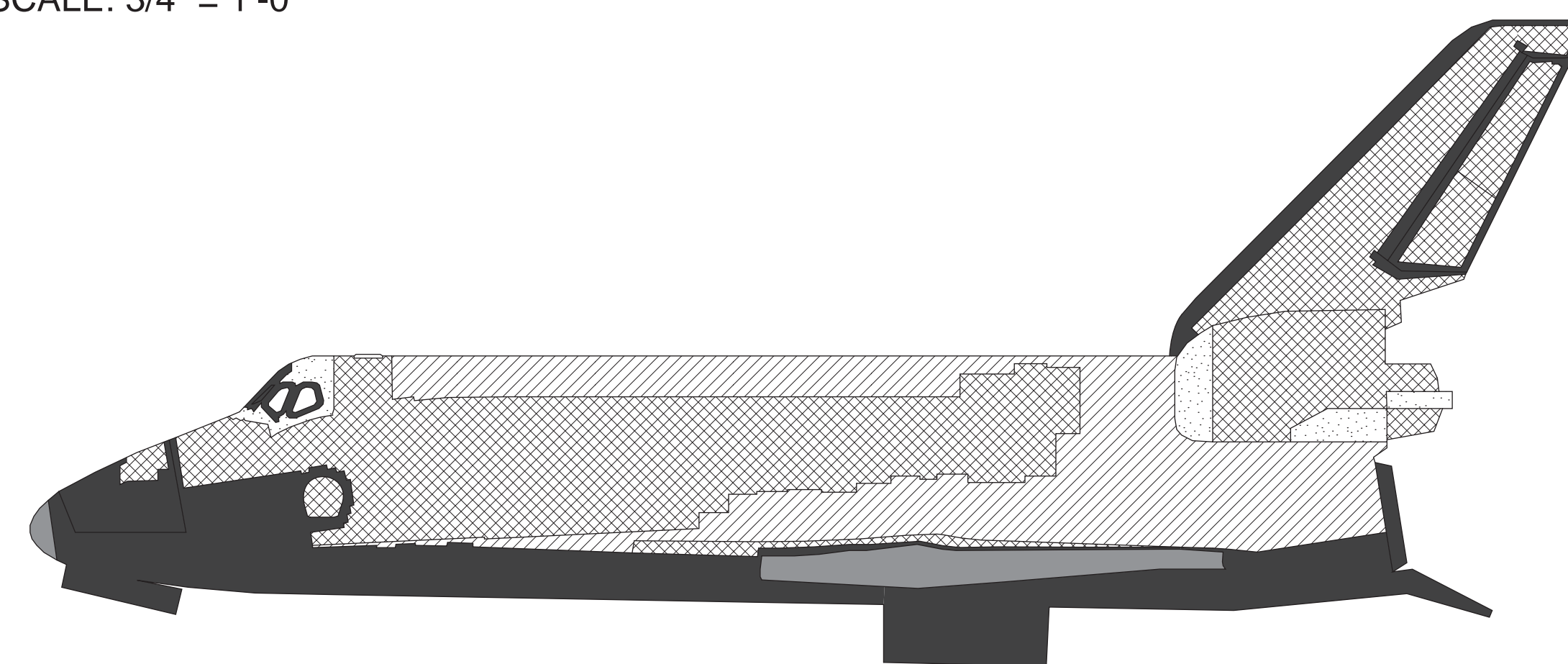

**PORT TPS COVER (TYP.)**  
SCALE: 3/32" = 1'-0"

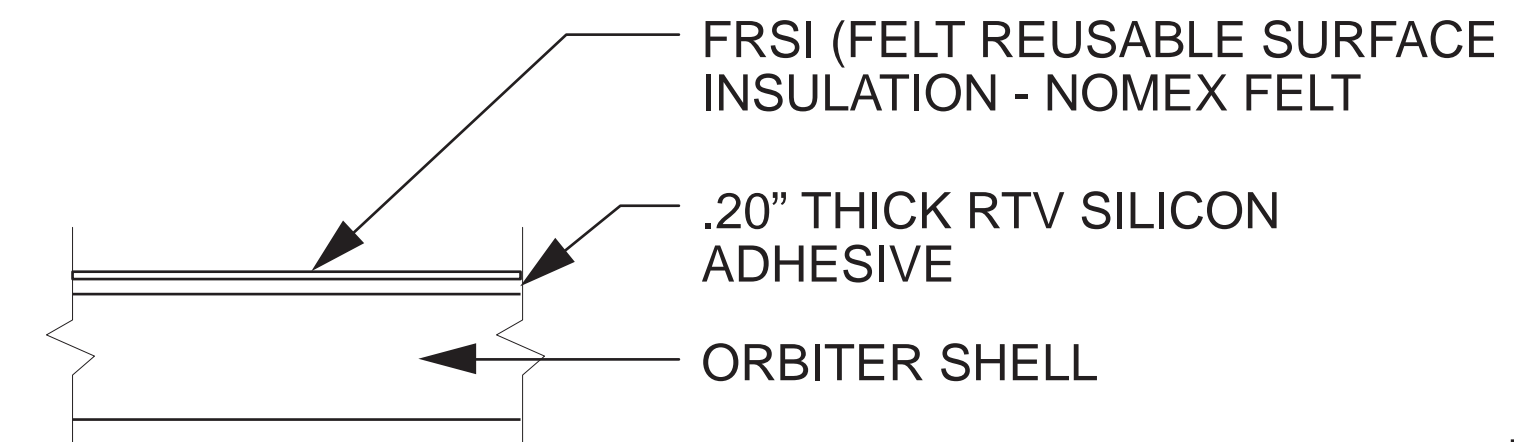

**FRSI - FLEXIBLE REUSABLE SURFACE INSULATION DETAIL**  
SCALE: 1-1/2" = 1'-0"

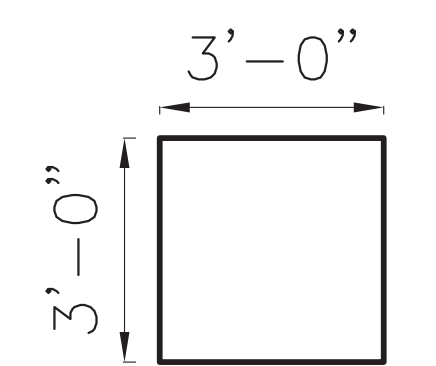

**AFRSI TYPICAL BLANKET SIZE**

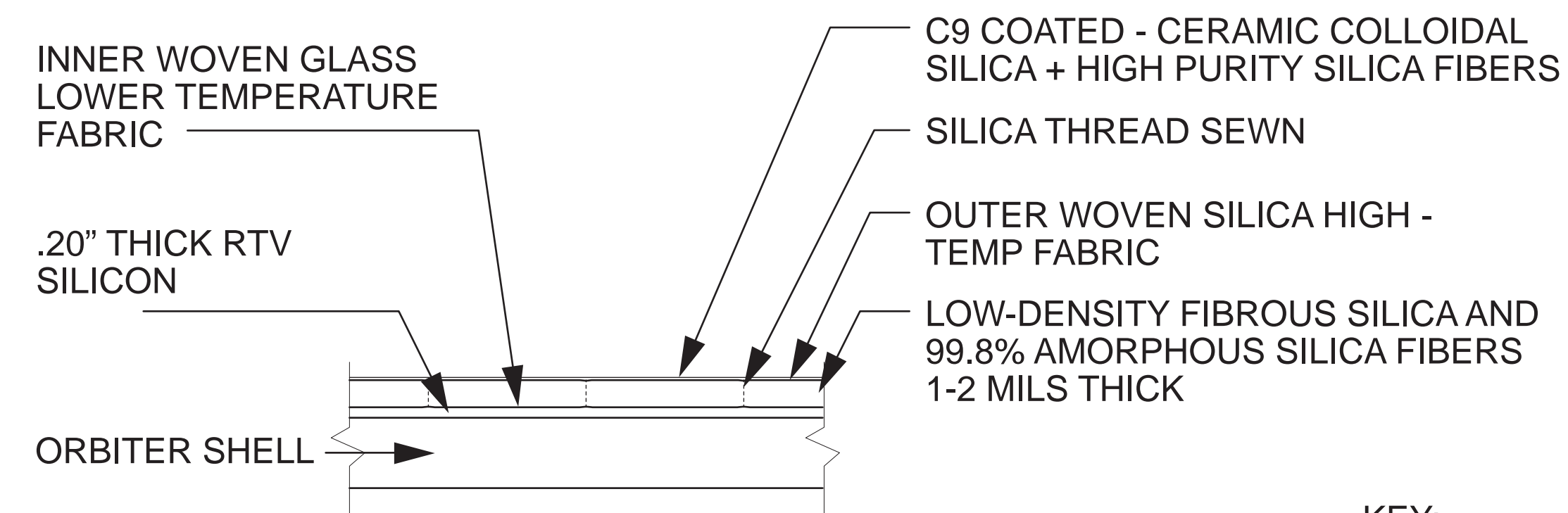

**AFRSI - ADVANCED FLEXIBLE REUSABLE SURFACE INSULATION DETAIL**  
SCALE: 1-1/2" = 1'-0"

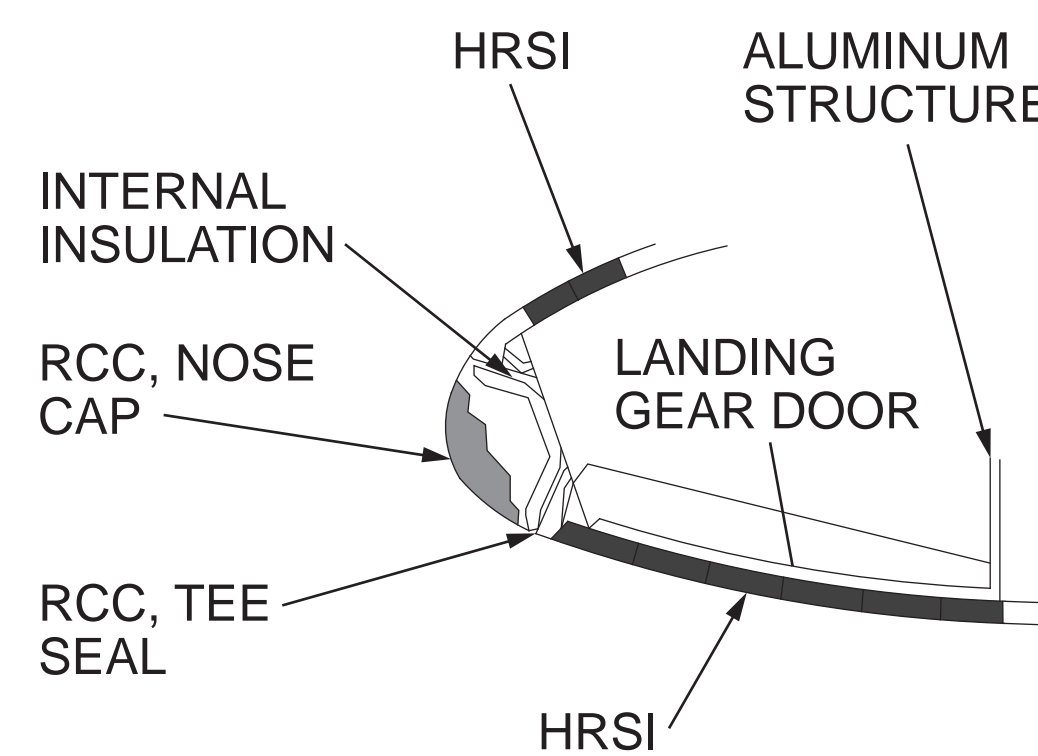

**NOSE SECTION A-A**

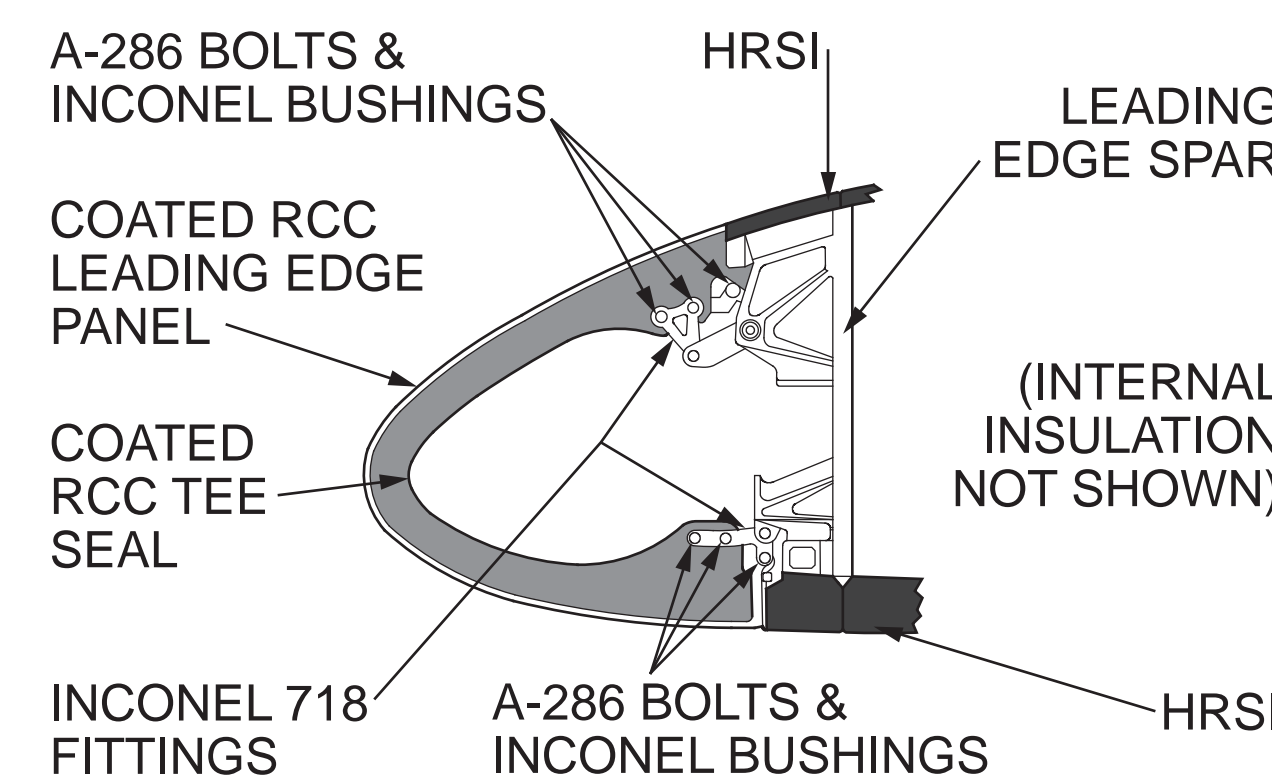

**WING SECTION B-B**

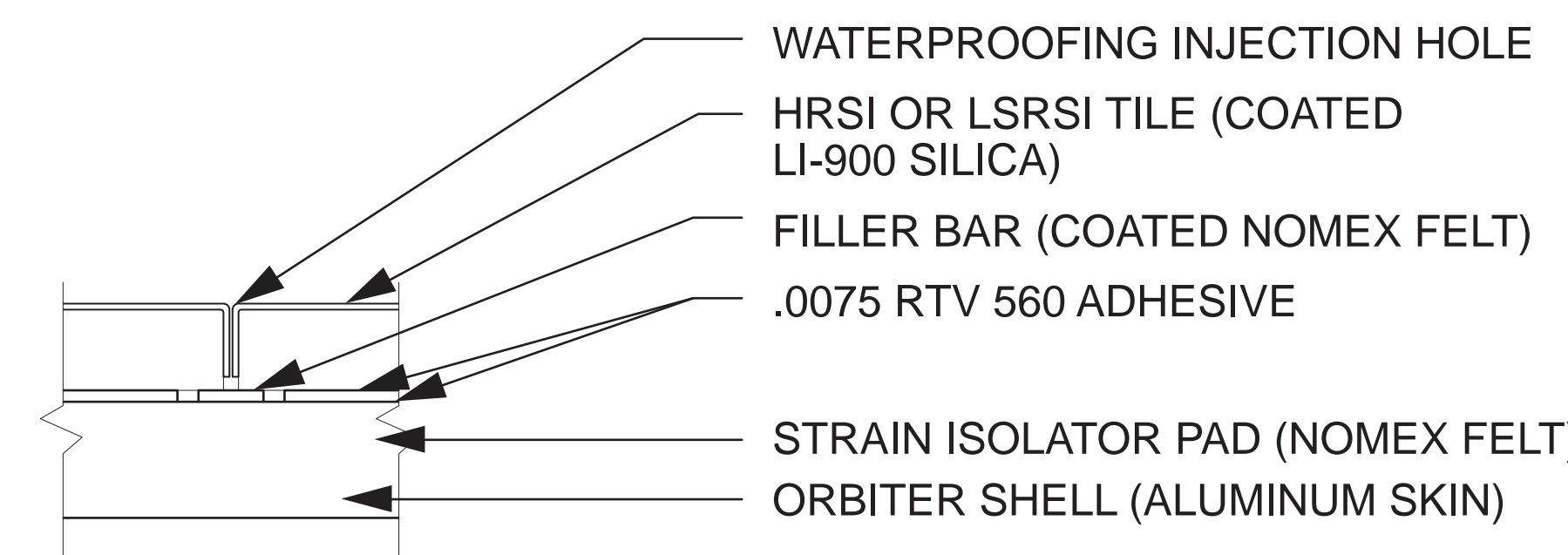

**HRSI/ LRSI = HIGH/ LOW TEMPERATURE REUSABLE SURFACE INSULATION DETAIL**  
SCALE: 1-1/2" = 1'-0"



**REINFORCED CARBON CARBON (RCC) COVER DETAIL**  
SCALE: 3/4" = 1'-0"

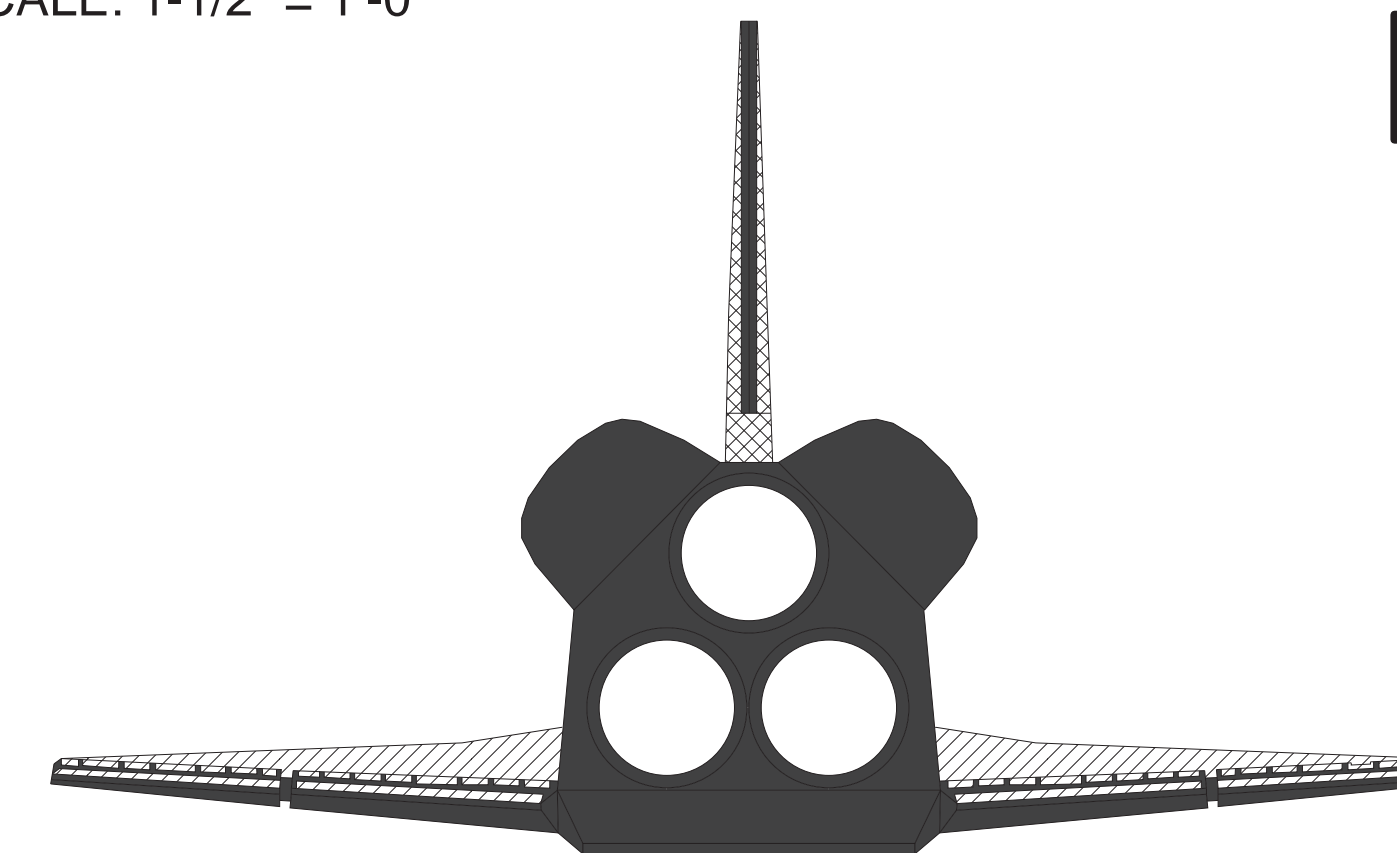

**REAR TPS COVER**  
SCALE: 3/32" = 1'-0"

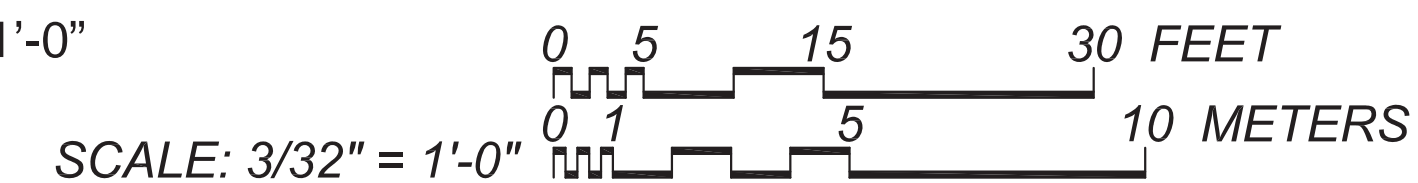

# ORBITER TCS: THERMAL CONTROL SYSTEM

A passive thermal control system helps maintain the temperature of the orbiter spacecraft, systems, and components within their temperature limits. This system uses available orbiter heat sources and sinks supplemented by insulation blankets, thermal coatings, and thermal isolation methods. Heaters are provided on components and systems in areas where passive thermal control techniques are not adequate.

The insulation blankets are of two basic types: Fibrous bulk and multilayer. The bulk blankets are fibrous materials with a density of 2 pounds per cubic foot and a sewn cover of reinforced acrylic film kapton. The cover material has 13,500 holes per square foot for venting. Acrylic film tape is used for cutouts, patching, and reinforcements. Tufts throughout the blankets minimize billowing during venting.

The multilayer blankets are constructed of alternate layers of perforated acrylic film kapton reflectors and Dacron net separators. There are 16 reflector layers in all. The two cover halves counting as two layers. Covers, tufting, and acrylic film tape are similar to that used for the bulk blankets.

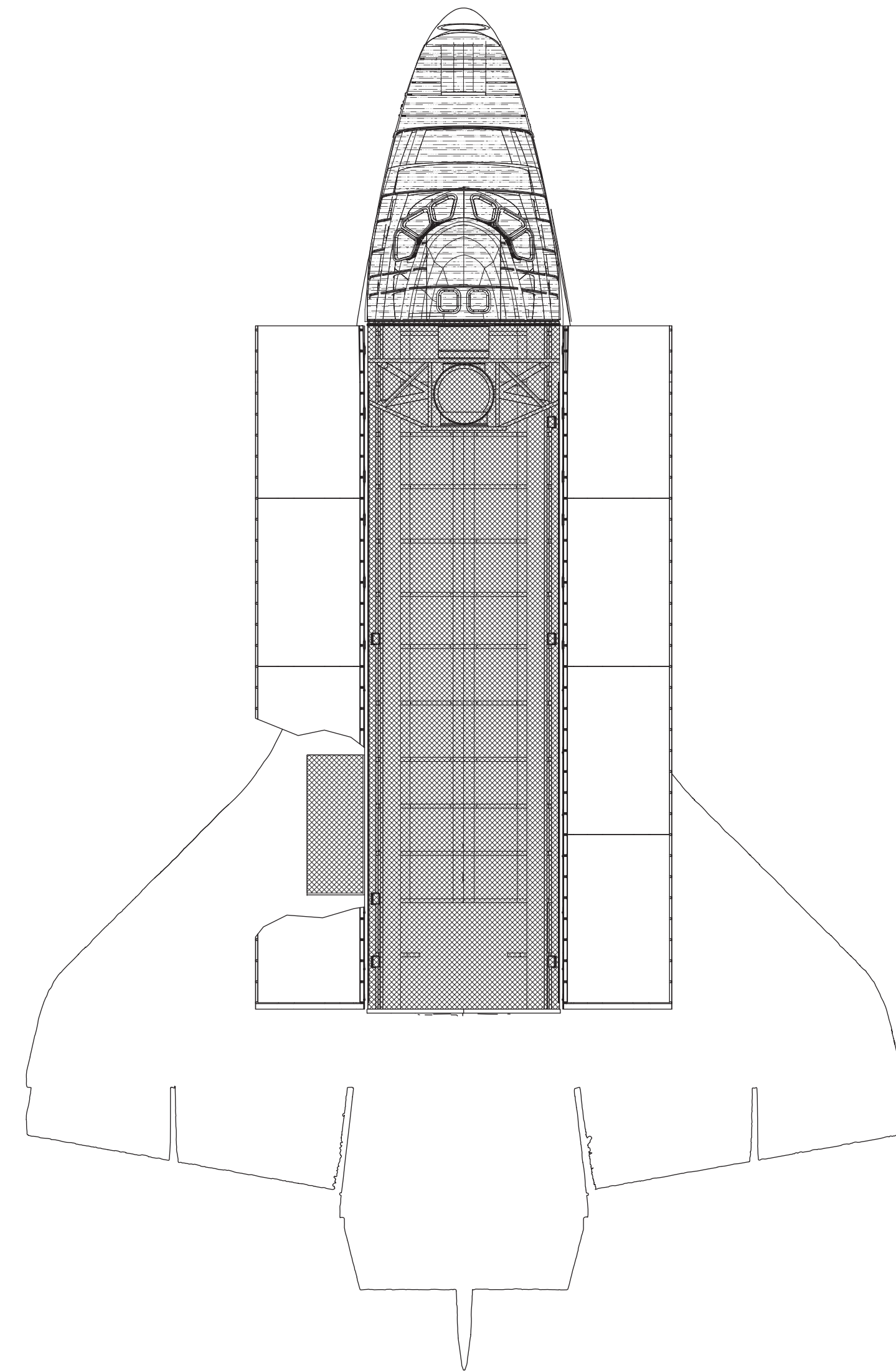

**BOTTOM/ TOP TCS COVER**  
SCALE: 3/32" = 1'-0"

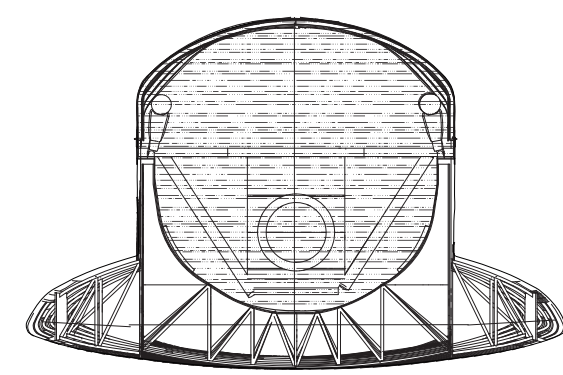
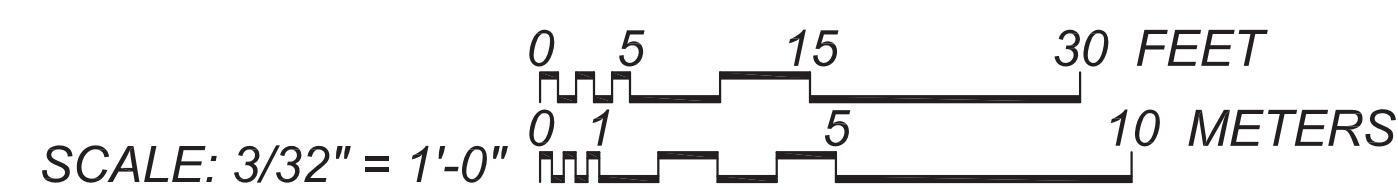

**FRONT TCS COVER**  
SCALE: 3/32" = 1'-0"

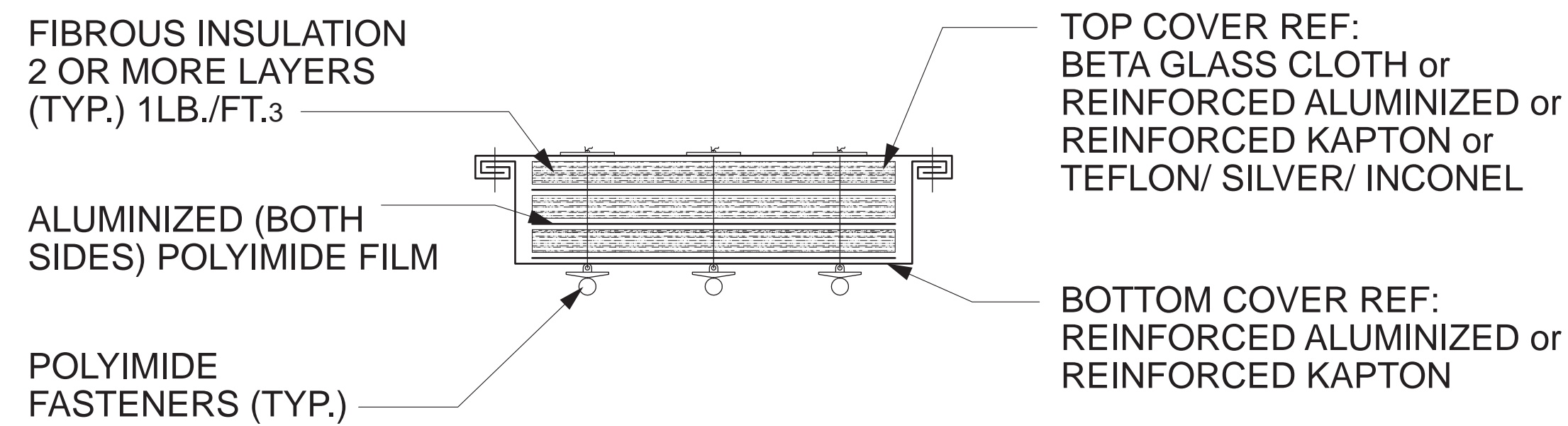

KEY:  
 **FIBROUS BLANKET DETAIL (TYP.)**  
SCALE: 1-1/2" = 1'-0"

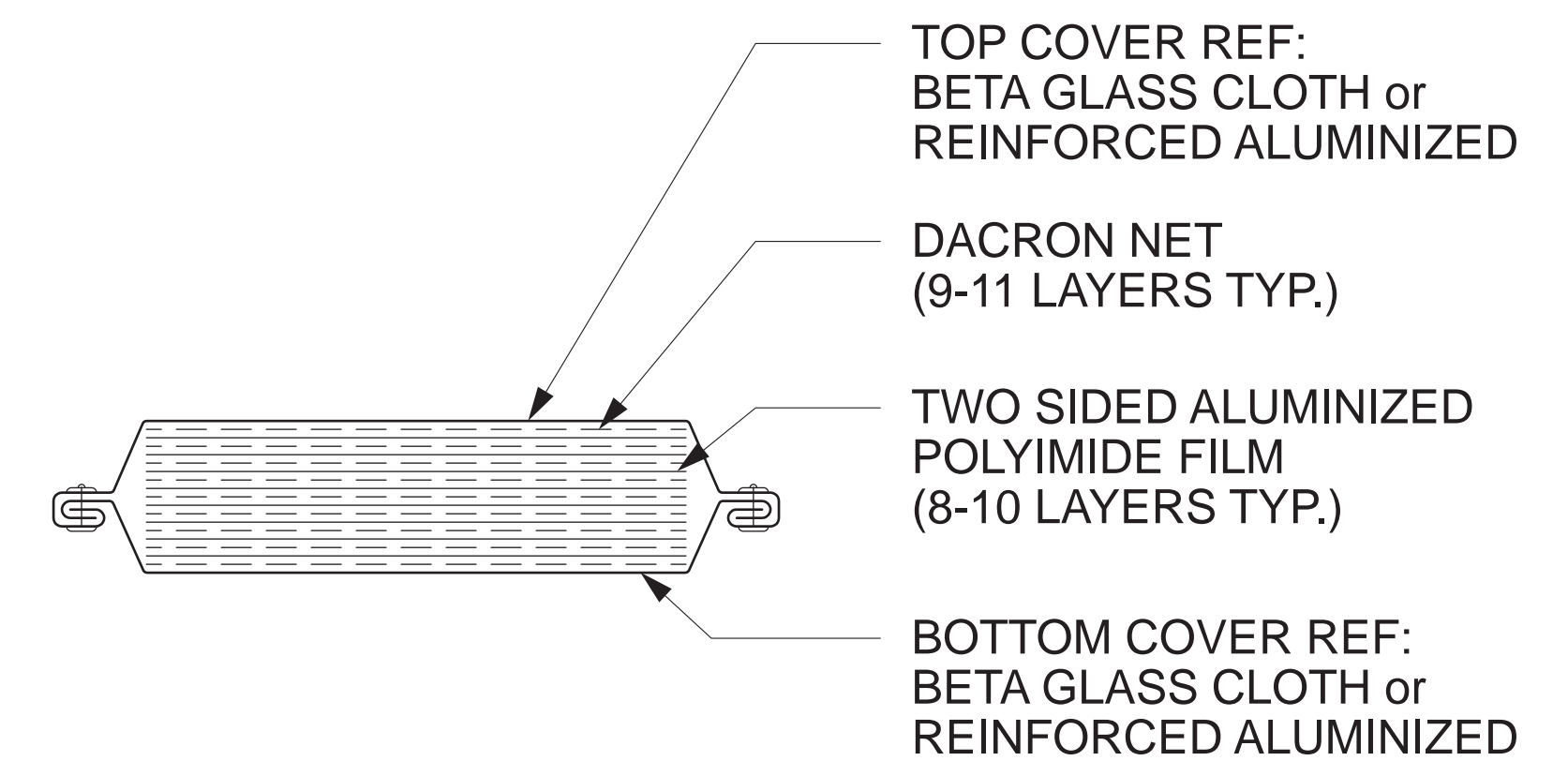

KEY:  
 **MLI - MULTILAYER TCS BLANKET DETAIL**  
SCALE: 1-1/2" = 1'-0"

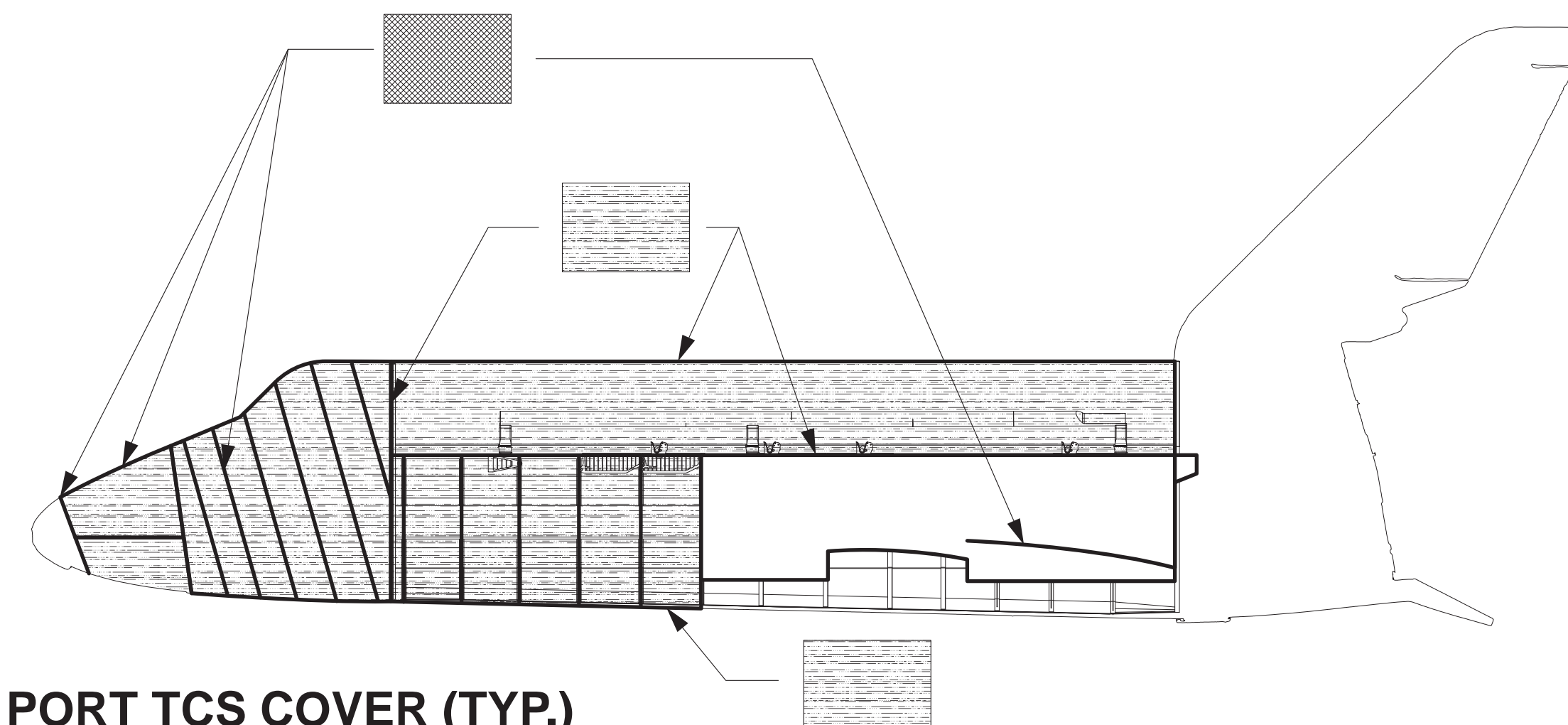

**PORT TCS COVER (TYP.)**  
SCALE: 3/32" = 1'-0"

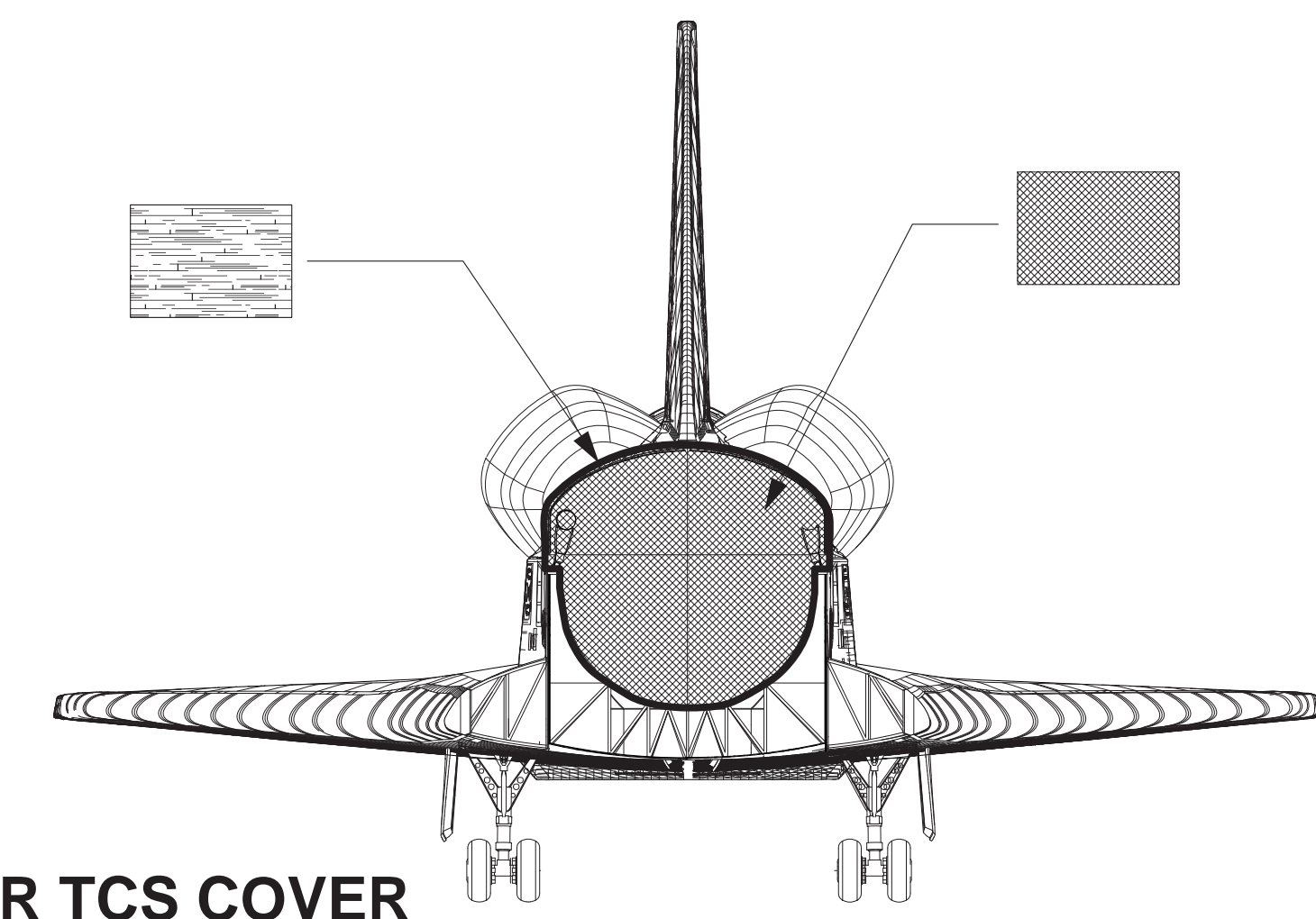

**REAR TCS COVER**  
SCALE: 3/32" = 1'-0"

### ENVIRONMENTAL CONTROL AND LIFE SUPPORT SYSTEMS

**PRESSURE CONTROL SYSTEM**

THE PRESSURE CONTROL SYSTEM MAINTAINS THE CREW COMPARTMENT AT 14.7 PSIA WITH A BREATHABLE MIXTURE OF OXYGEN AND NITROGEN. NITROGEN IS ALSO USED TO PRESSURIZE THE SUPPLY AND WASTEWATER TANKS.

**ATMOSPHERIC REVITALIZATION SYSTEM**

THE ATMOSPHERIC REVITALIZATION SYSTEM USES AIR CIRCULATION AND WATER COOLANT LOOPS TO REMOVE HEAT, CONTROL HUMIDITY, AND CLEAN AND PURIFY CABIN AIR.

**ACTIVE THERMAL CONTROL SYSTEM**

THE ACTIVE THERMAL CONTROL SYSTEM CONSISTS OF TWO FREON LOOPS THAT COLLECT WASTE HEAT FROM THE ORBITER SYSTEMS AND TRANSFER THE HEAT OVERBOARD.

**SUPPLY & WASTE WATER SYSTEM**

THE SUPPLY AND WASTE WATER SYSTEM STORES WATER PRODUCED BY THE FUEL CELLS FOR DRINKING, PERSONAL HYGIENE, AND ORBITER COOLING. THE WASTEWATER SYSTEM STORES CREW LIQUID WASTE AND WASTEWATER FROM THE HUMIDITY SEPARATOR. THE SYSTEM ALSO HAS THE CAPABILITY TO DUMP SUPPLY AND WASTEWATER OVERBOARD.

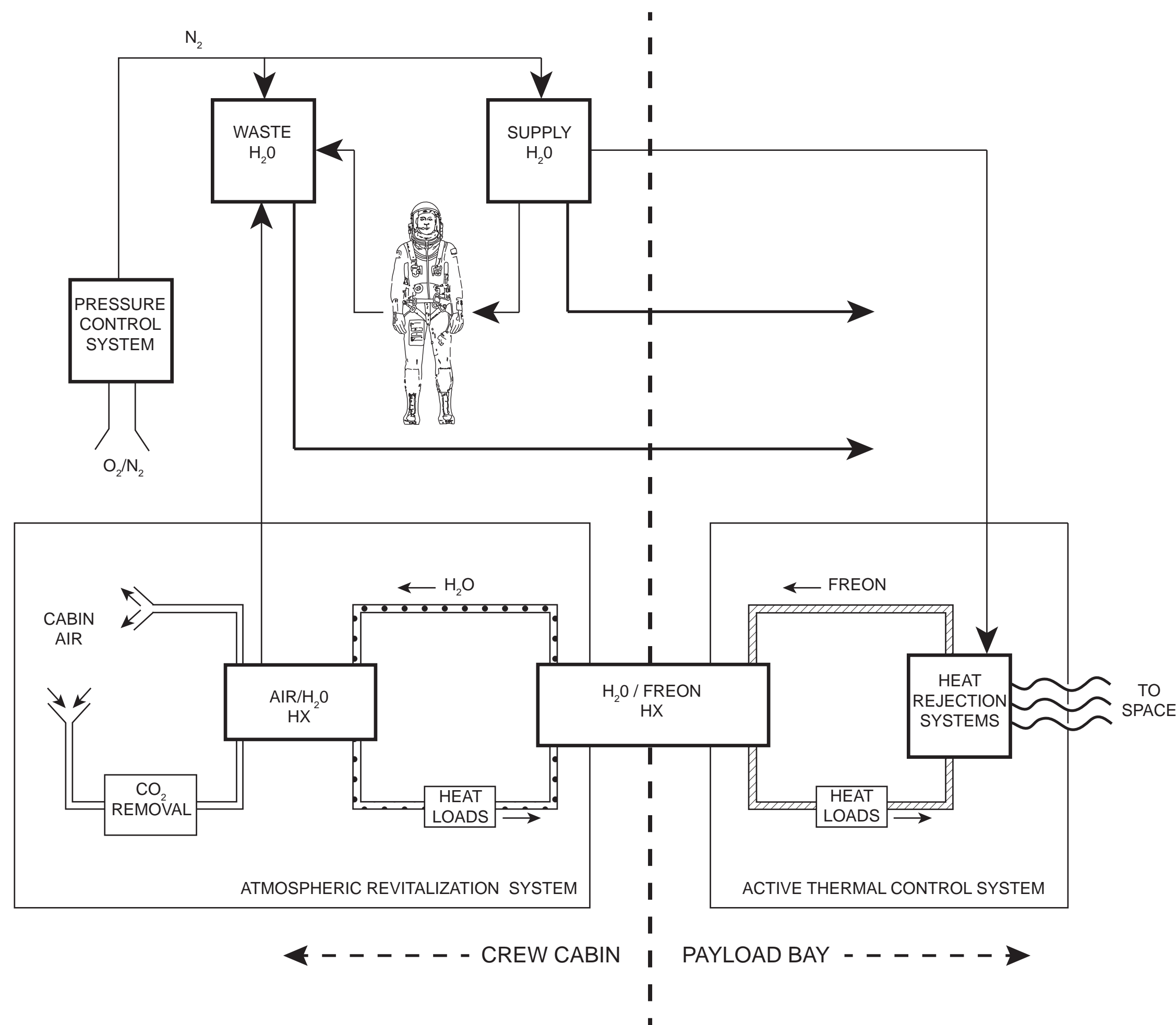

### ELECTRICAL POWER SYSTEMS

**FUEL CELL POWER PLANTS**

**POWER REACTANTS AND DISTRIBUTION**

**ELECTRICAL POWER DISTRIBUTION & CONTROL**

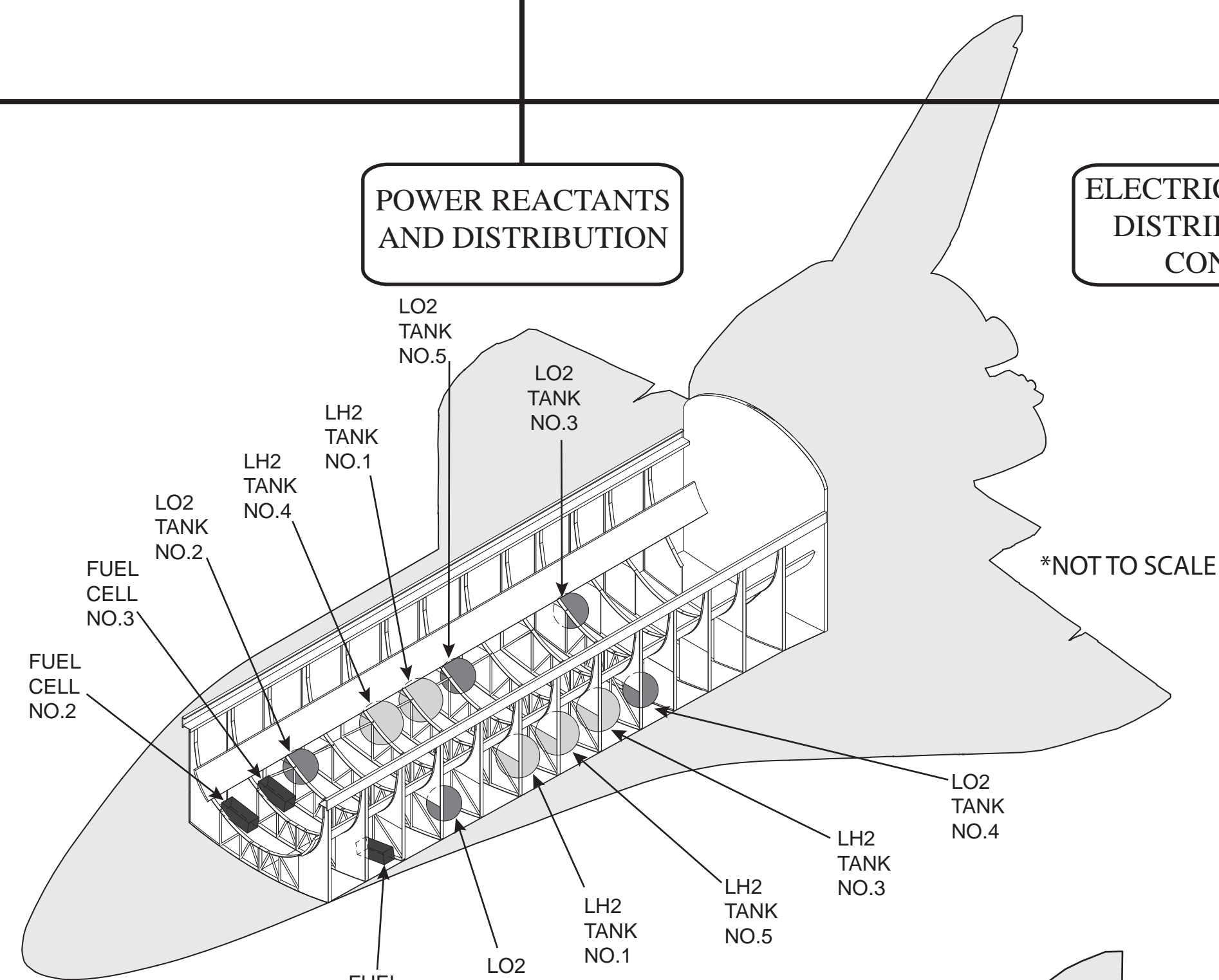

### AUXILIARY POWER

**AUXILIARY POWER UNIT**

**FUEL TANK**

**AUXILIARY POWER UNIT CONTROLLER**

- SSME GIMBAL
- SSME CONTROL VALVES
- AEROSURFACES
- ET UMBILICAL RETRACT
- LANDING GEAR
- LANDING GEAR BRAKES
- NOSE WHEEL STEERING

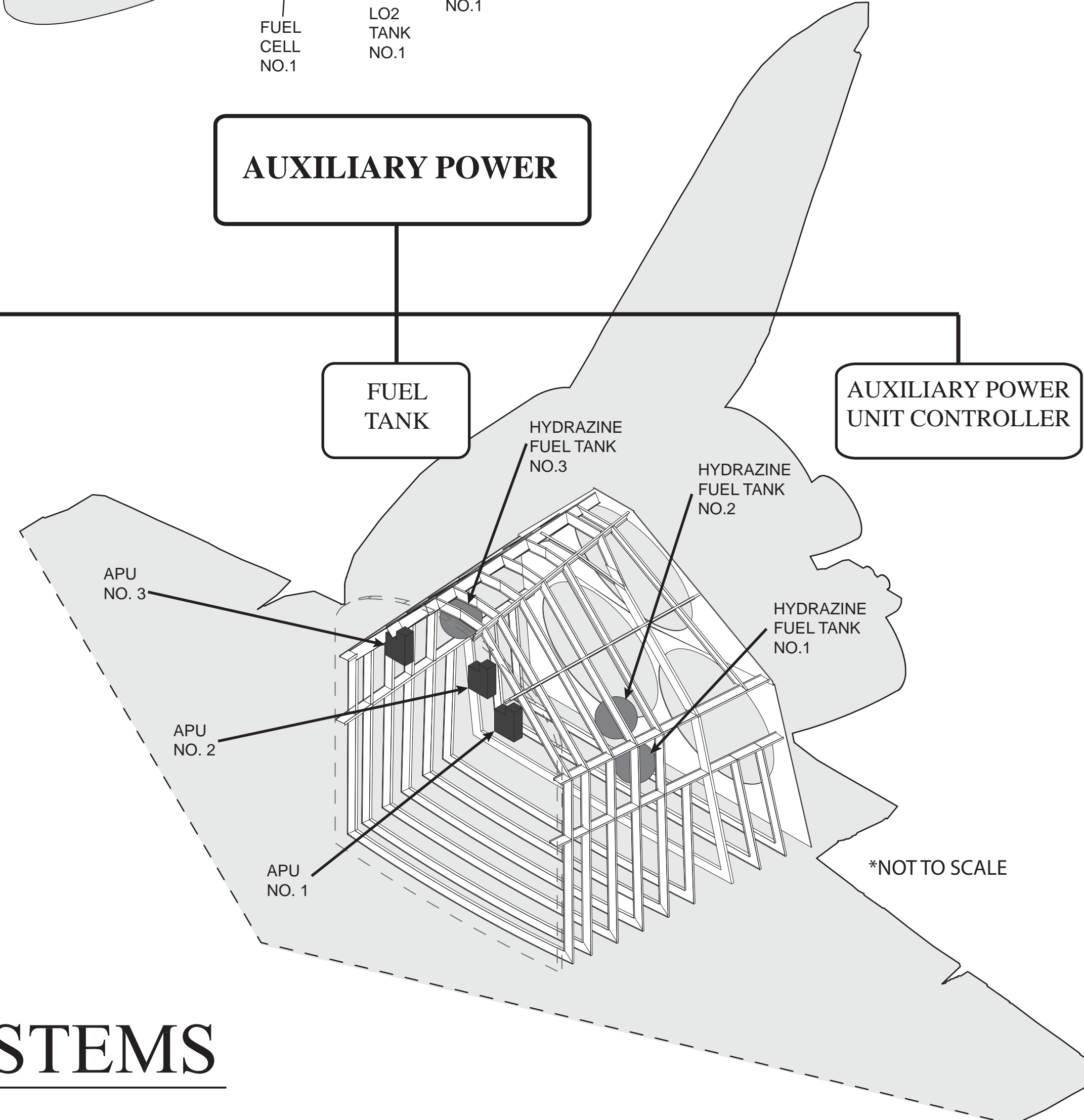

## ECLSS AND POWER SYSTEMS

RELEASED - Printed documents may be obsolete; validate prior to use.