

Space Transportation System Solid Rocket Boosters



Orbiter Discovery just after launch of STS-121 from Kennedy Space Center, Florida. Image courtesy of NASA Johnson Space Center. Photographer unknown

During the thirty-year operation of the Space Transportation System, the Solid Rocket Boosters (SRBs) were the largest solid-propellant rockets ever used, the first designed for reuse, and the only solid-propellant rocket motors ever certified for manned spaceflight.

Each SRB measured about 149 feet long and 12 feet in diameter and could generate approximately 3,300,000 pounds of thrust at sea level. The SRBs were used as matched pairs, and each was made up of four solid rocket motor segments. The boosters were matched by loading each of the four motor segments in pairs from the same batches of propellant ingredients to minimize any thrust imbalance. The propellant mixture consisted of: aluminum powder fuel; ammonium perchlorate oxidizer; iron oxide catalyst, a synthetic polymer binding agent and an epoxy curing agent. The propellant was molded in a star-shaped perforation in the forward motor segment and a double-truncated cone perforation in the aft segment and aft closure. This configuration provided high thrust at ignition and reduced thrust approximately 50 seconds after launch, during the period of maximum dynamic pressure on the stack assembly.

The segmented-casing design assured maximum flexibility in fabrication and ease of transportation and handling. Once each segment was insulated, cast with propellant and finalized, the segments were shipped from ATK's manufacturing facility in Utah to Kennedy Space Center (KSC) in Florida, on specially designed, heavy-duty covered rail cars. At KSC, they were stacked and assembled into the

flight configuration. In addition to the four fueled segments there was the forward section and an aft section. The forward section contained avionics systems, electronic assemblies integrated with the aft segment and descent parachutes.

The aft segment contained an electronic assembly that sends and receives signals to and from the avionics system in the forward segment, the rocket motor's expansion nozzle and mechanisms for the gimbaling of the nozzles. The SRB nozzles had an approximate 7.75 to 1 expansion ratio and were lined with a sacrificial carbon cloth that was charred and eroded during flight. The nozzles could gimbal up to 8 degrees for thrust vector control. To actuate the gimbals each SRB had its own auxiliary power unit and hydraulic pumps.

At approximately 2 minutes and 8 seconds after launch the SRBs had consumed their fuel and were jettisoned. At jettison eight small separation rocket motors, four on the forward section and four on the aft section fired for about one second to alter their trajectory to ensure there is no incidental contact with the Orbiter or External Tank. At a predetermined altitude three parachutes were deployed on each SRB assembly to reduce the velocity of their descent to lessen their impact at splashdown. Shortly after splashdown, two booster recovery ships, the Freedom Star and Liberty Star, arrive with crews to plug, drain and prepare the SRBs to be towed back to KSC for post-launch inspection, processing and preparation for transport back to ATK in Utah.

This recording project is part of the Historic American Engineering Record (HAER), a long-range program to document historically significant engineering, industrial, and maritime works in the United States. The HAER program is administered by the National Park Service, U.S. Department of the Interior. The Space Transportation System recording project was cosponsored during 2011 by the Space Shuttle Program Transition and Retirement Office of the Johnson Space Center (JSC), with the guidance and assistance of Barbara Severance, Integration Manager, JSC, Jennifer Groman, Federal Preservation Officer, NASA Headquarters and Ralph Allen, Historic Preservation Officer, Marshall Space Flight Center. The field work and measured drawings were prepared under the general direction of Richard O'Connor, Chief, Heritage Documentation Programs, National Park Service. The project was managed by Thomas Behrens, HAER Architect and Project Leader. The Space Transportation System Recording Project consisted architectural delineators, John Wachtel, Iowa State and Joseph Klimek, Illinois Institute of Technology. This documentation is based on high-definition laser scans provided by Smart GeoMetrics, Houston, Texas and documentation provided by NASA's Headquarters, Johnson Space Center and Marshall Space Flight Center. Written historical and descriptive data was provided by Archaeological Consultants Inc., Sarasota, Florida. Large-format photographs were produced by NASA's Imaging Lab at Johnson Space Center with supplemental images provided by Jet Lowe, HAER photographer.

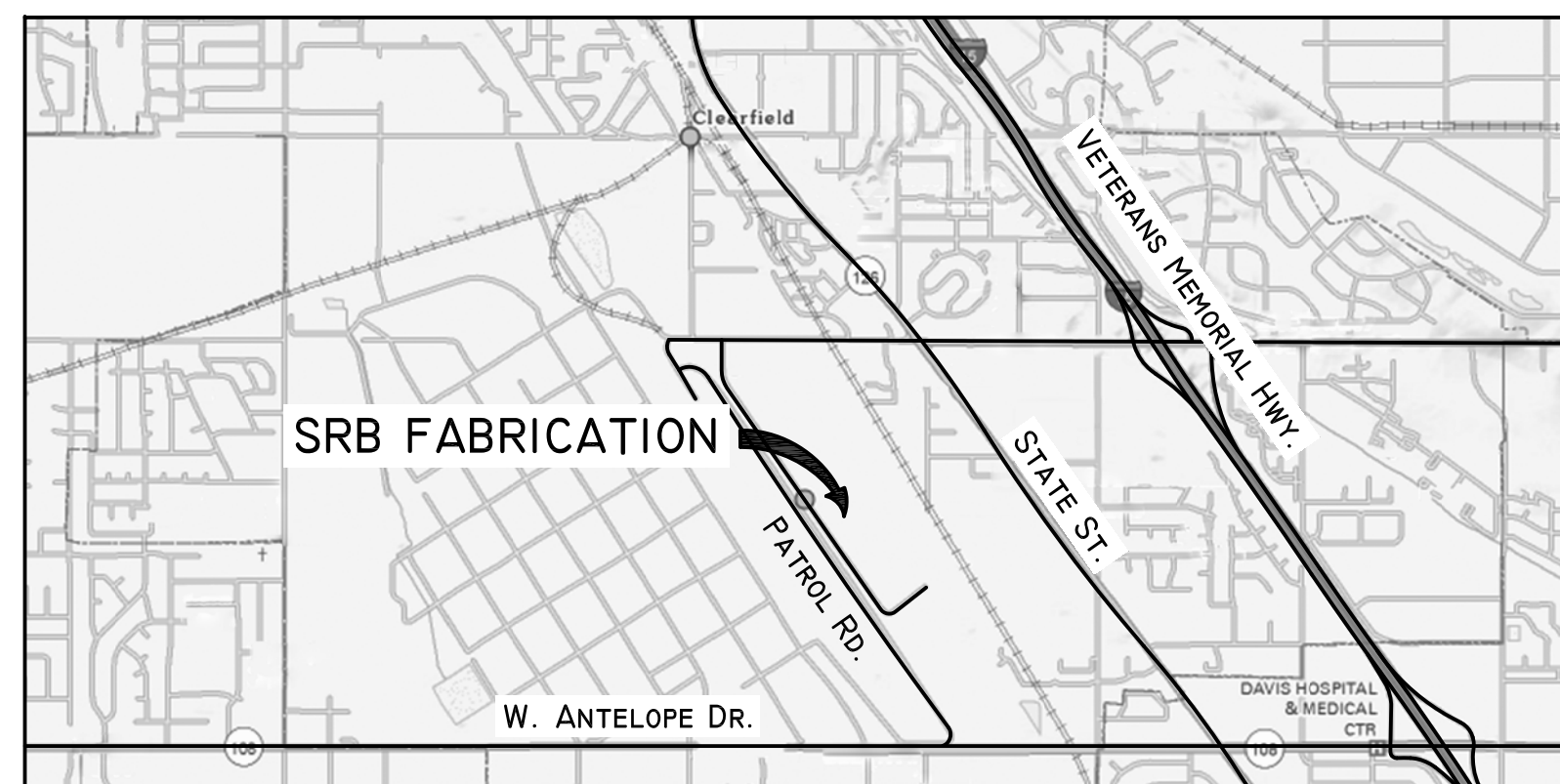

VICINITY MAP CLEARFIELD, UTAH

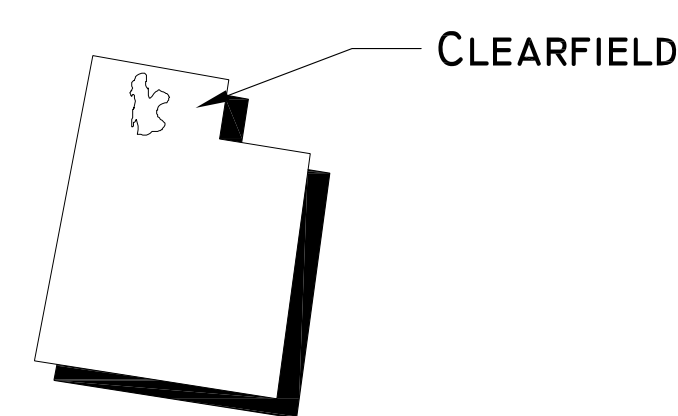

UTAH

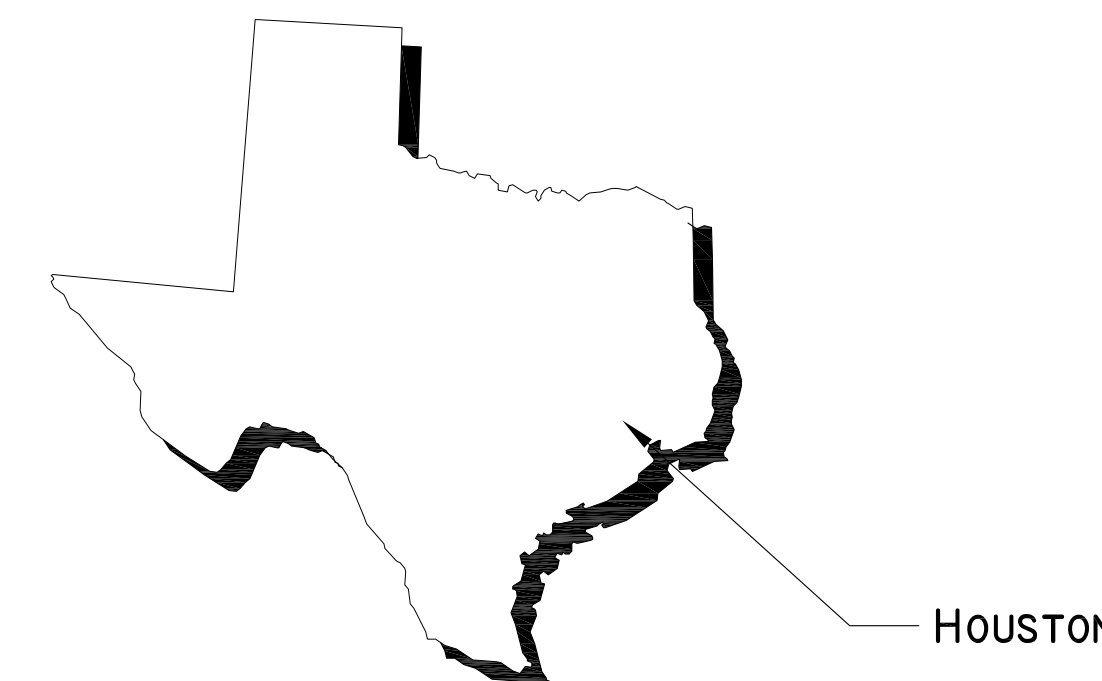

TEXAS

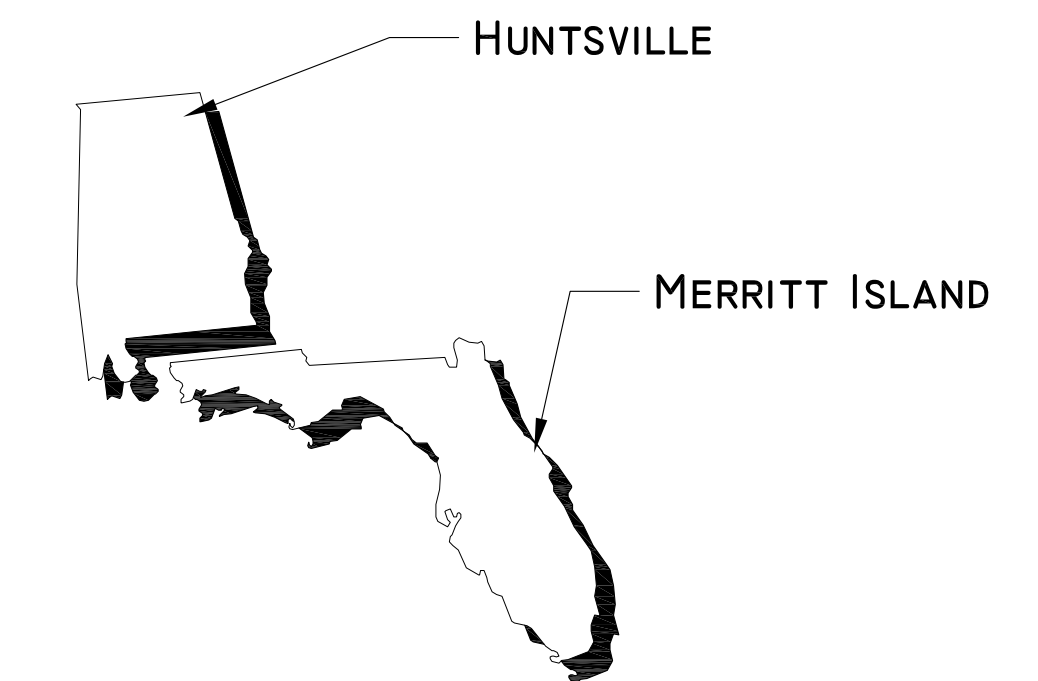

ALABAMA

FLORIDA

- (A) NOZZLE AND THRUST VECTOR CONTROL SYSTEM
- (B) FWD EXTERNAL TANK ATTACH POINT
- (C) AFT EXTERNAL TANK ATTACH RING
- (D) 4 SEPARATION MOTORS
- (E) MAIN PARACHUTES (3)
- (F) THERMAL CURTAIN
- (G) SYSTEMS TUNNEL
- (H) DROGUE CHUTE
- (I) AFT SKIRT

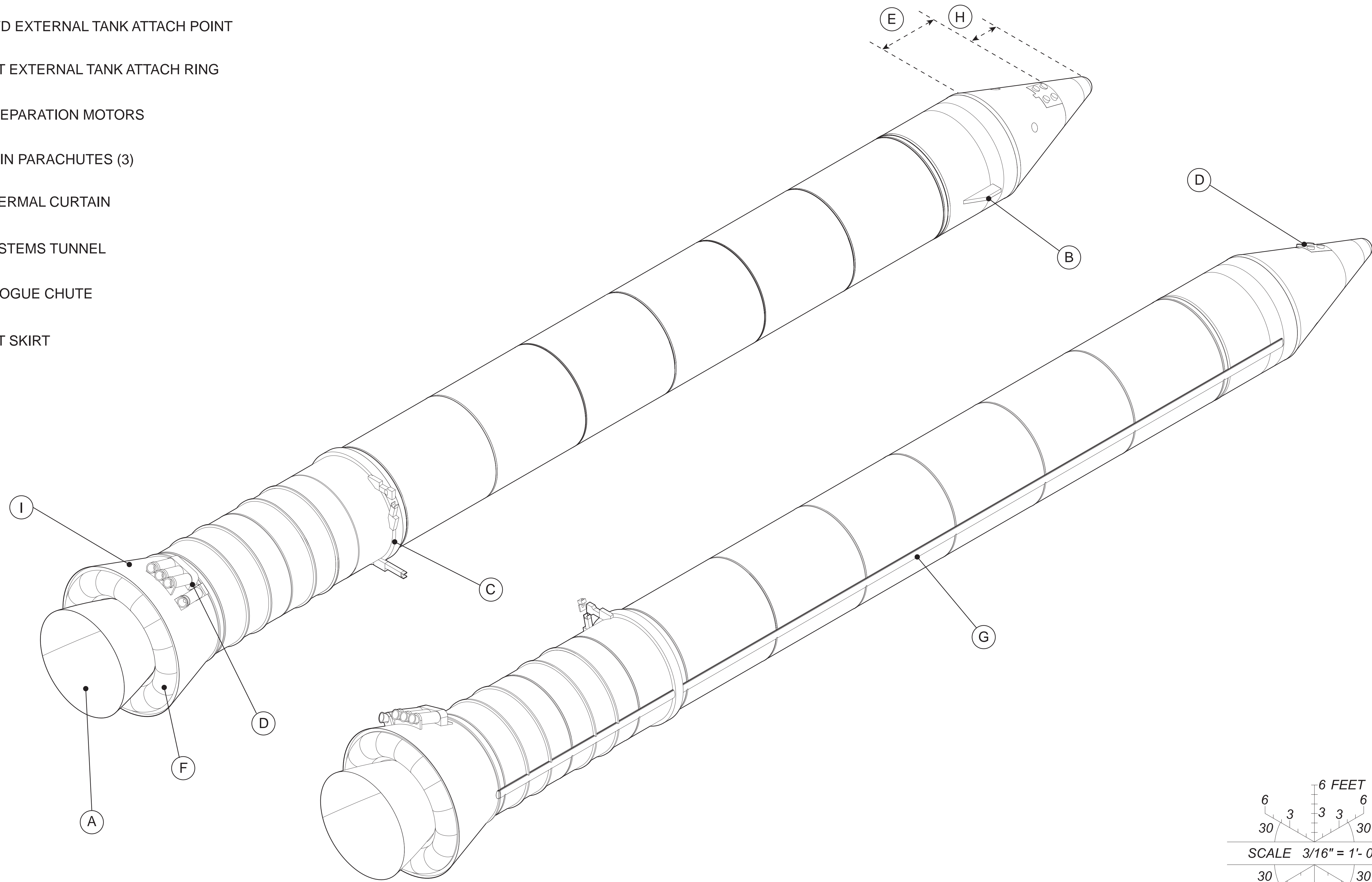

SOLID ROCKET BOOSTERS

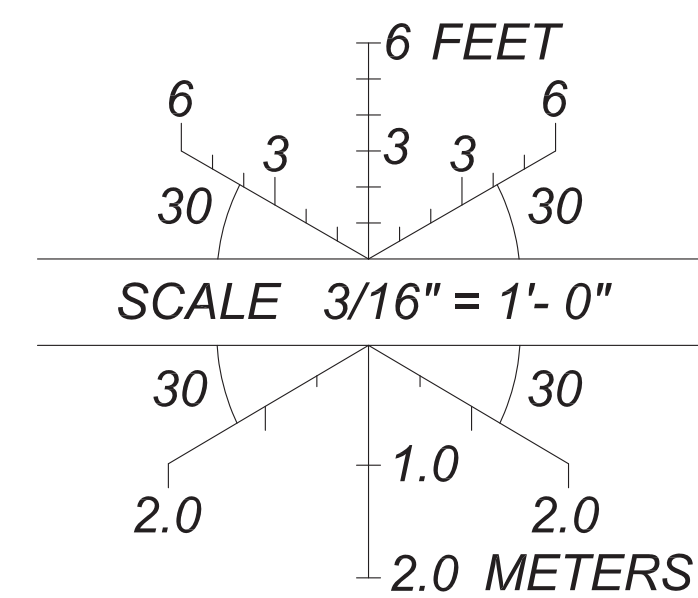

DELINEATED BY: JOHN WACHTEL, JOSEPH KLIMEK
 SPACE TRANSPORTATION SYSTEM
 RECORDING PROJECT
 NATIONAL PARK SERVICE
 UNITED STATES DEPARTMENT OF THE INTERIOR

HOUSTON

SPACE TRANSPORTATION SYSTEM SOLID ROCKET BOOSTERS
 JOHNSON SPACE CENTER, 2101 NASA PARKWAY
 HARRIS COUNTY TEXAS

SHEET 2 OF 3

HISTORIC AMERICAN
 ENGINEERING RECORD
 TX-116-K

IF REPRODUCED PLEASE CREDIT THE HISTORIC AMERICAN ENGINEERING RECORD, NATIONAL PARK SERVICE, NAME OF DELINEATOR, DATE OF DRAWING

SOLID ROCKET BOOSTERS (SRB)

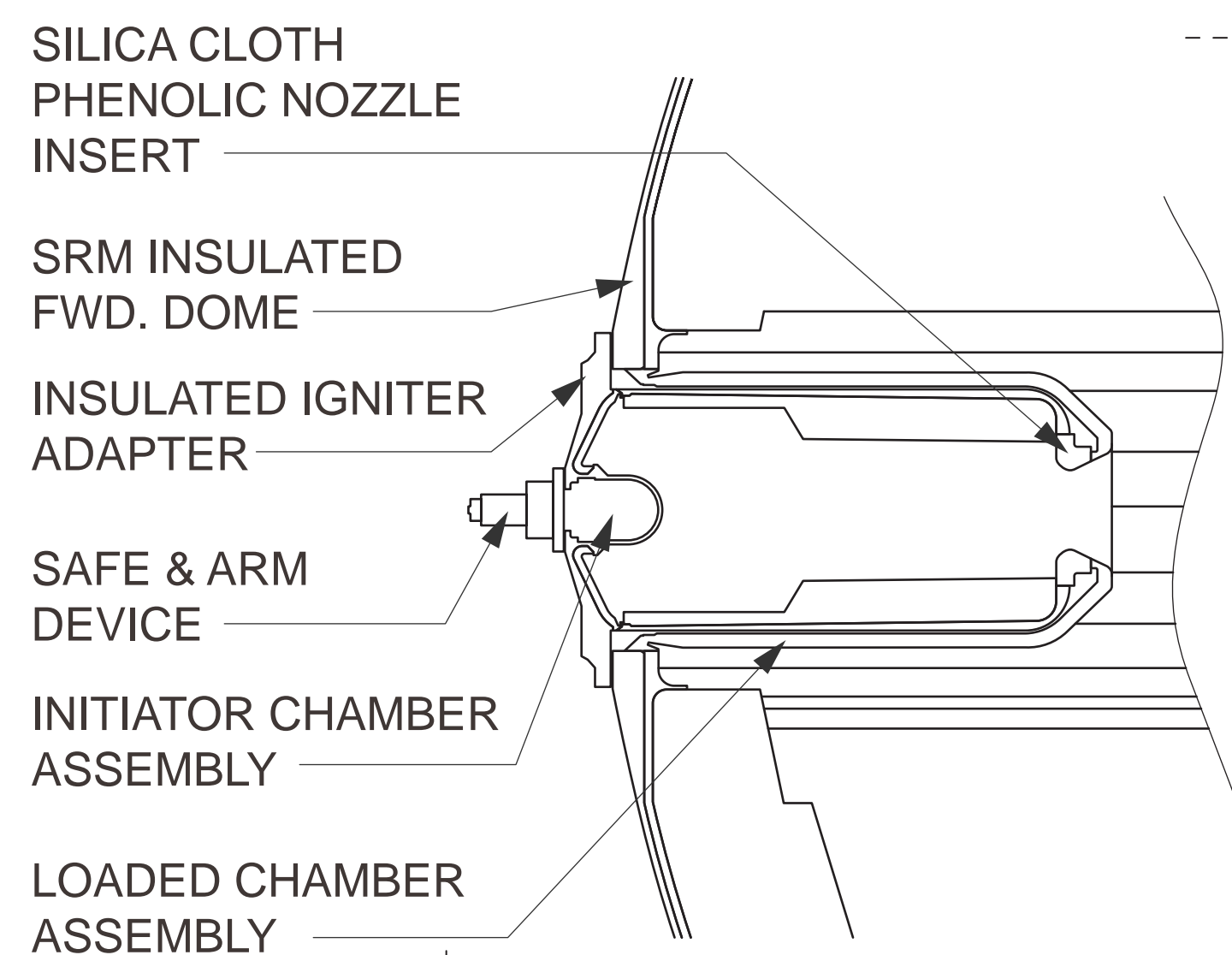

SRB IGNITOR DETAIL
SCALE: 1" = 1'-0"

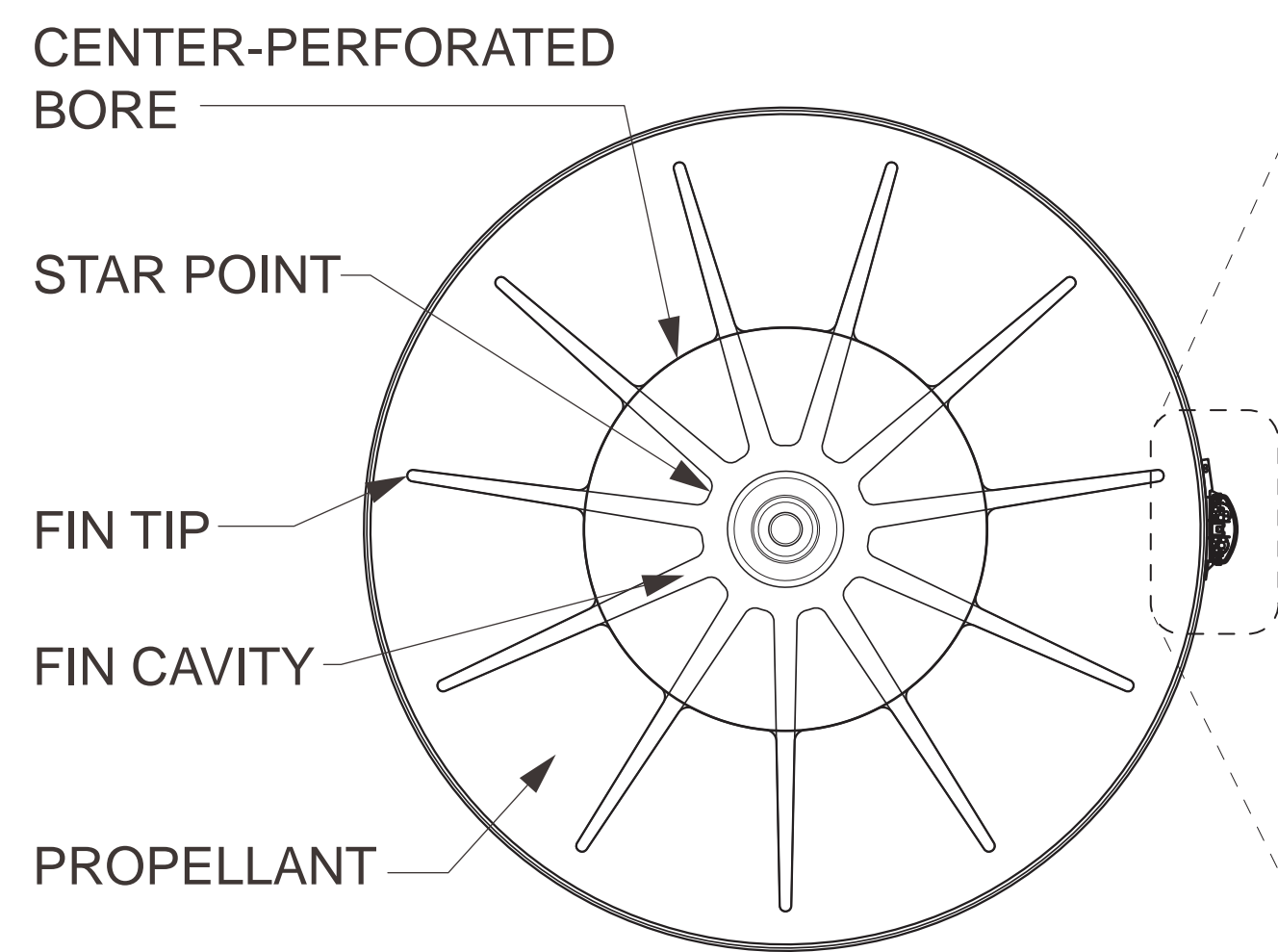

SRB LATERAL SECTION A-A
SCALE: 3/8" = 1'-0"

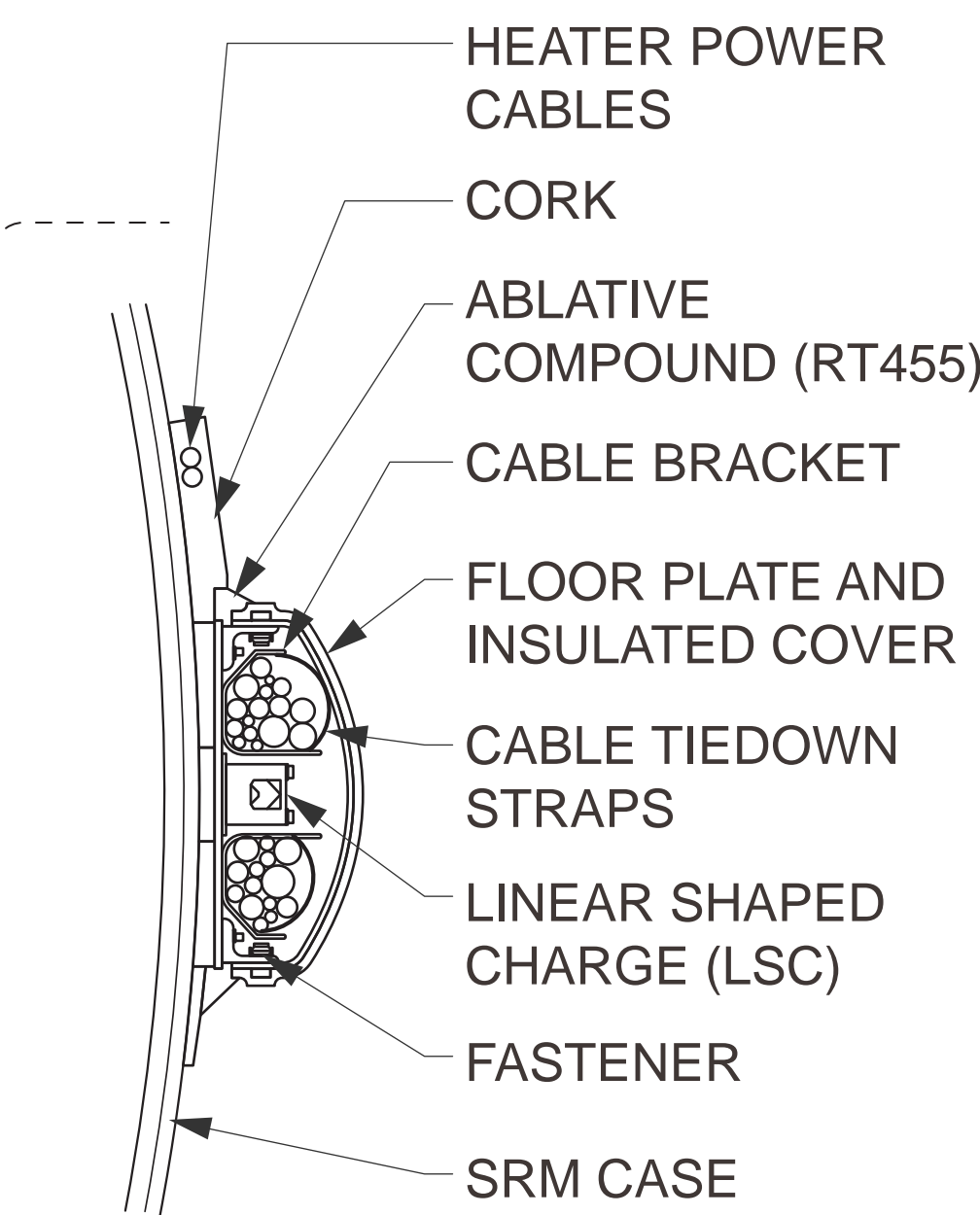

SYSTEM TUNNEL DETAIL
SCALE: 2" = 1'-0"

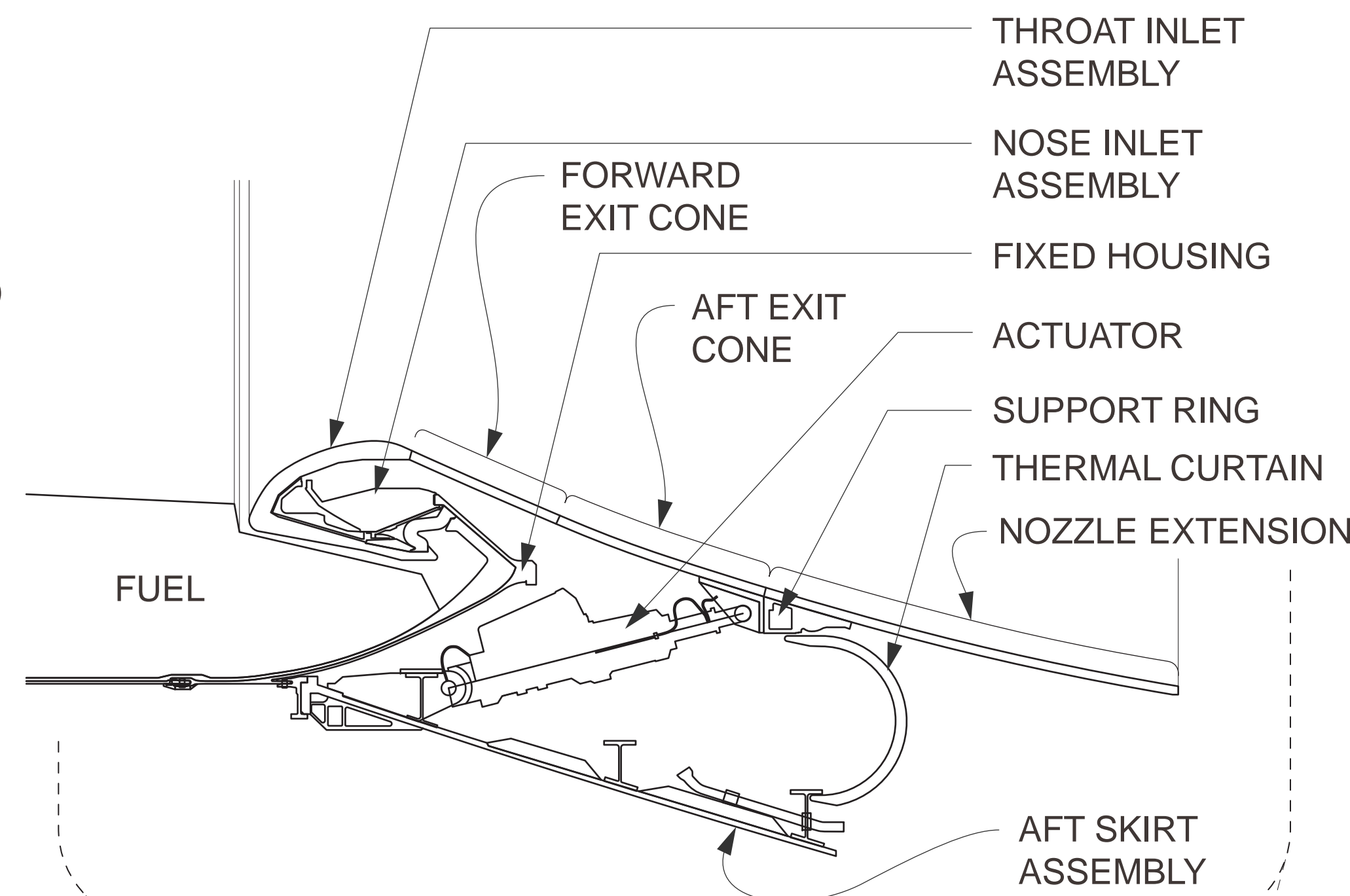

SRB ROCKET AFT DETAIL
SCALE: 1/2" = 1'-0"

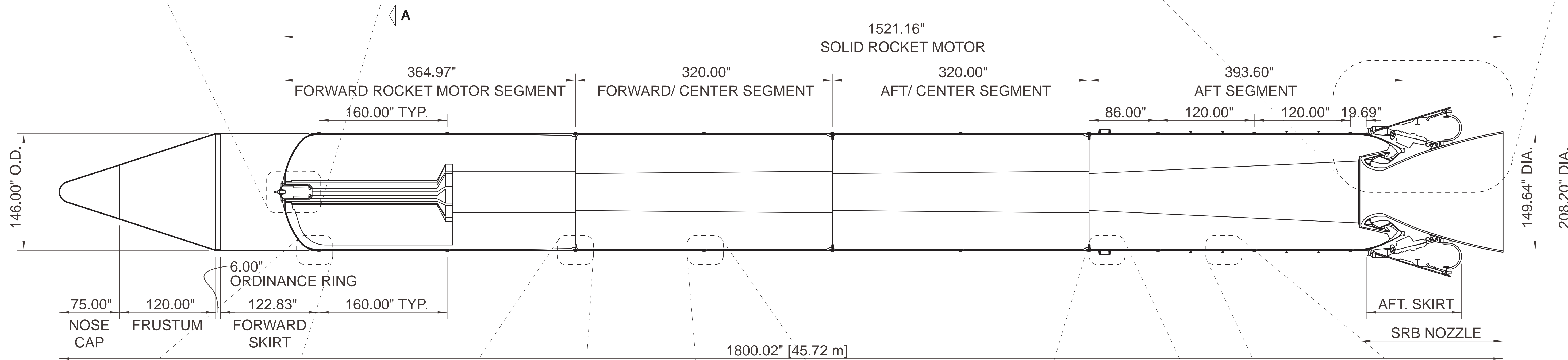

SRB LONGITUDINAL SECTION
SCALE: 3/16" = 1'-0"

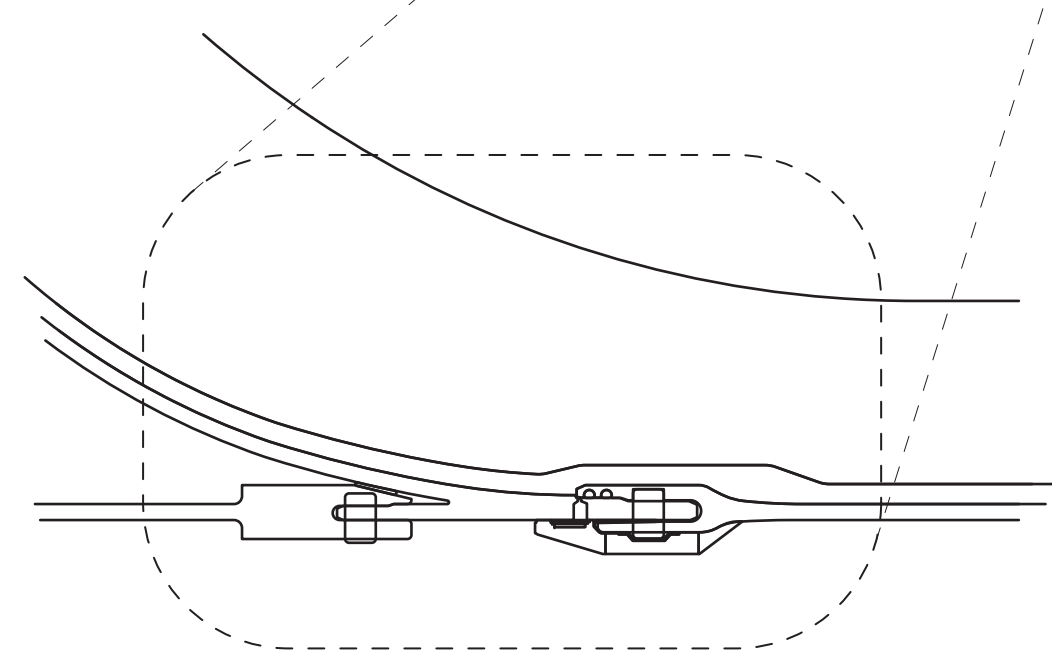

NOSE TO TANK
SCALE: 2" = 1'-0"

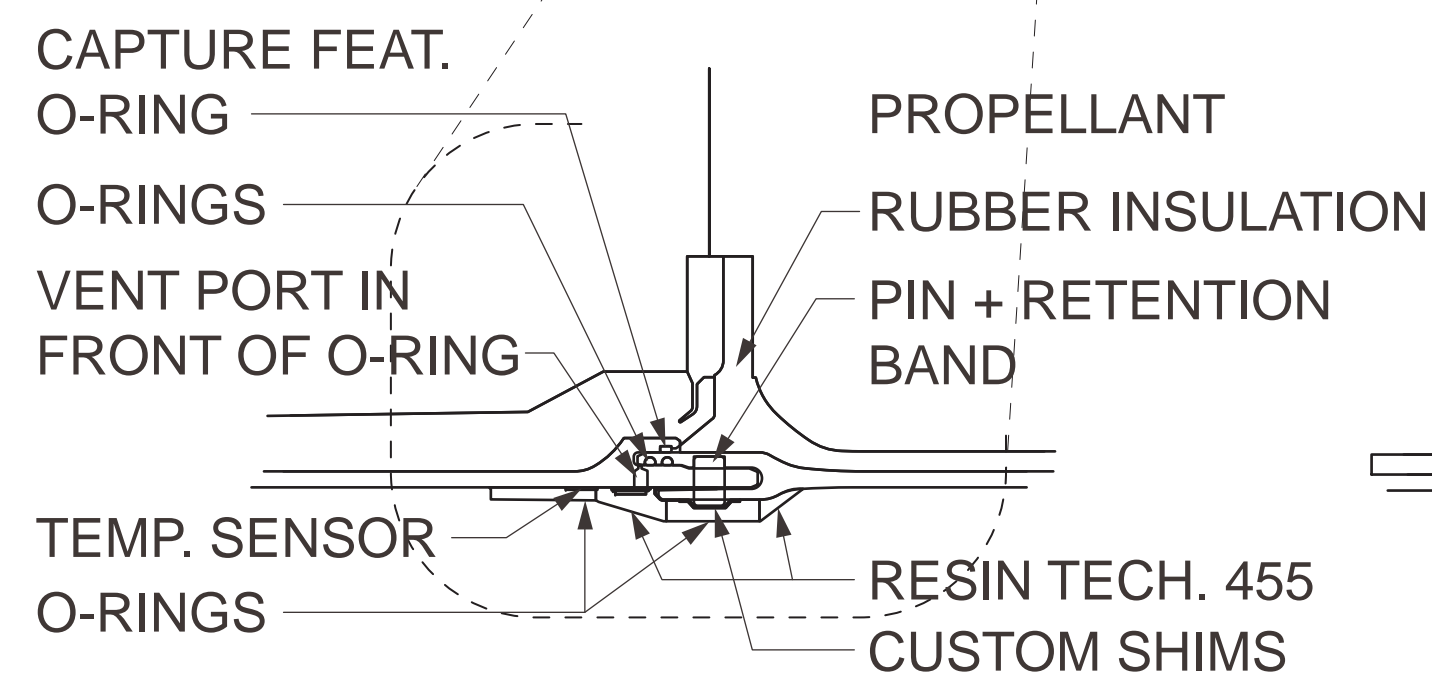

FIELD WELD JOINT
SCALE: 2" = 1'-0"

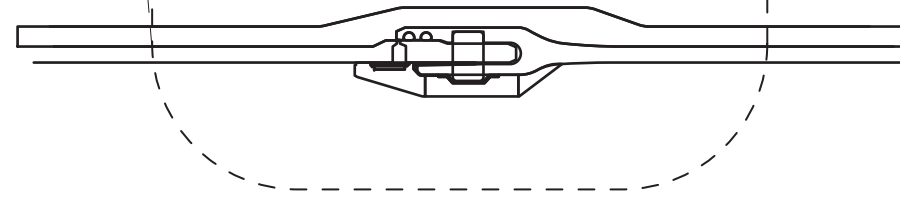

FACTORY WELD JOINT
SCALE: 2" = 1'-0"

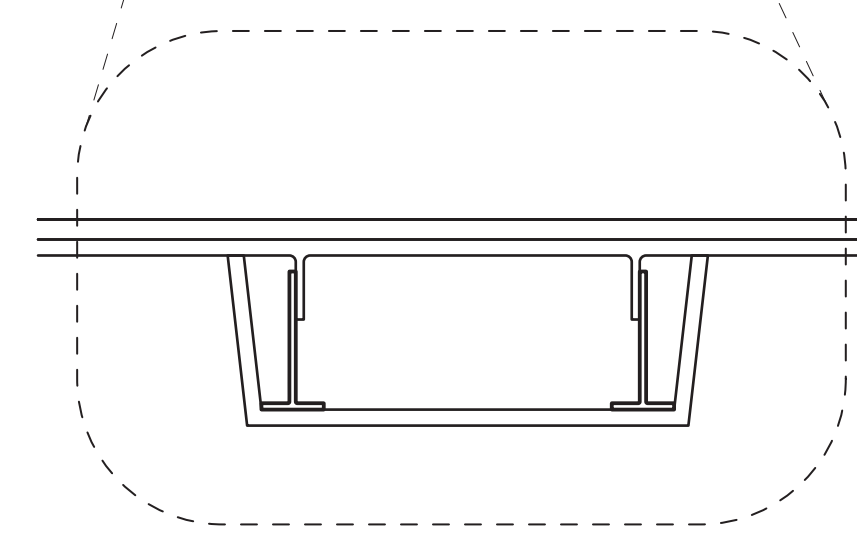

INTEGRATED ELECTRONIC ASSEMBLY (IEA)
SCALE: 2" = 1'-0"

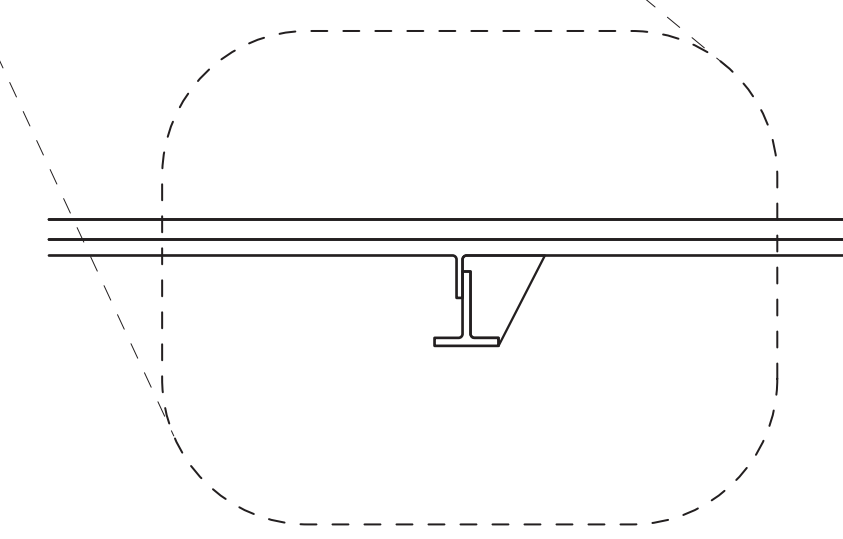

CASE STIFFENER RINGS
SCALE: 2" = 1'-0"