

Space Transportation System Stack Assembly

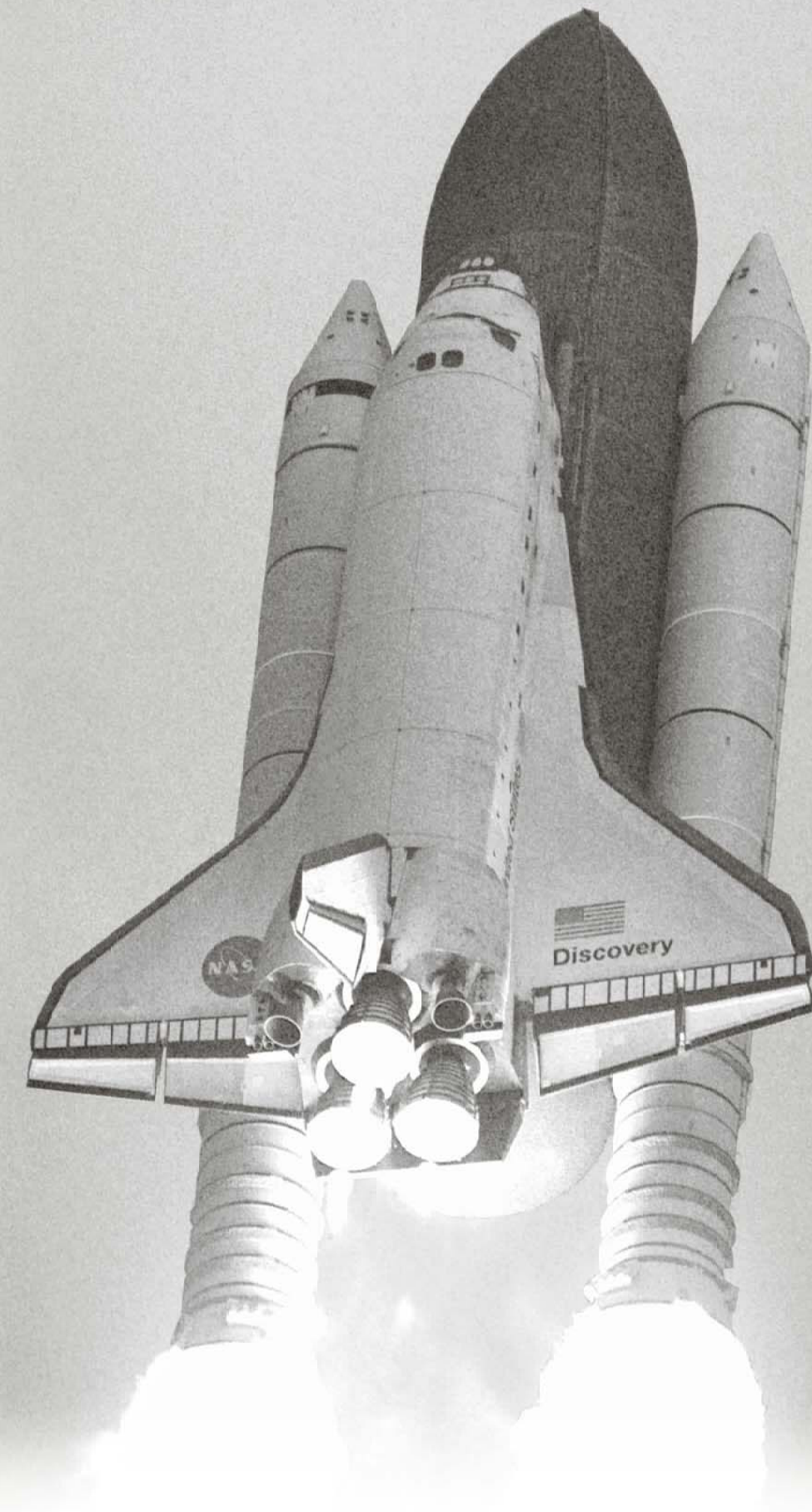
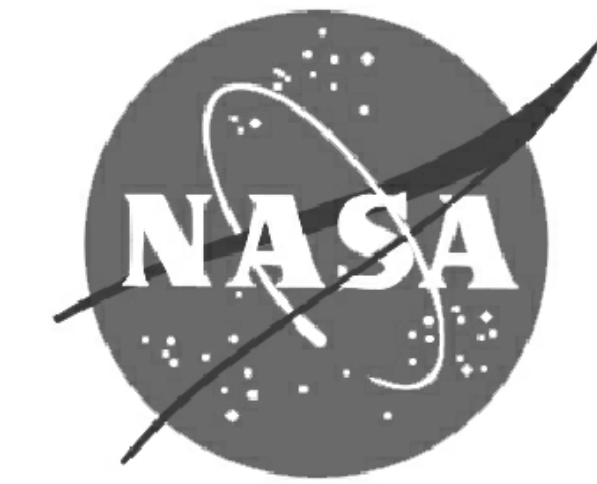

Orbiter Discovery just after launch of STS-96 from Kennedy Space Center, Florida. Image courtesy of NASA Johnson Space Center. Photographer unknown

Development of the Space Shuttle began in 1969 and a contract for the construction of the Space Shuttle was awarded in July 1972. The Space Shuttle launch configuration, or Stack Assembly, was comprised of four main components, the Orbiter Vehicle (OV), built by North American Rockwell (later Boeing), three Space Shuttle Main Engines (SSMEs), built by Rocketdyne (later Boeing), two Solid Rocket Boosters (SRBs) built by Thiokol (later ATK Launch Systems) and an External Tank (ET) built by Martin Marietta (later Lockheed Martin). Of these four components only the external tank was not re-usable.

During prelaunch preparations in the Vehicle Assembly Building (VAB), the SRBs were attached to the Mobile Launch Platform (MLP) at their aft skirts with four frangible nuts that were severed by explosive charges at liftoff. The ET was then attached to the SRBs at the booster aft attachment rings and at a point near the SRBs forward skirt. The Orbiter was then mated to the SRB/ET assembly at the ET via attach points near the propellant and electrical umbilical connections on the Orbiter's aft fuselage and an attach point behind its nose landing-gear door on the forward fuselage. As a result, the SRBs carried the entire weight of the stack and transferred it through their structure to the MLP.

A complete Stack Assembly measured 184.2 feet from the base of the SRB's aft skirt to the nose of the ET. The depth of the assembly, from the exterior edge of the ET to the tip of the Orbiter's vertical stabilizer was 78.6 feet and the width of the assembly was 78.06 feet from wing tip to wing tip of the Orbiter.

When the prelaunch activities at the Vehicle Assembly Building were complete, a Crawler Transporter was used to lift the MLP, with the Stack Assembly attached, and carry it out to launch complex 39 A or B for further launch preparations.

At launch, the two SRB's provided the majority of the thrust required for liftoff. With a combined thrust of 6,600,000 pounds of force, the SRBs contributed approximately 72% of the power through the first launch stage, which ended at SRB separation, about 2 minutes after launch. After separation and at a predetermined altitude parachutes were deployed to slow the boosters' descent for safe splashdowns in the ocean about 141 nautical miles downrange, where they were retrieved, refurbished and reused for subsequent launches.

The orbiter's Main Propulsion System consisted of the External Tank, propellant delivery and control systems and three SSMEs which produced a combined thrust of 1,181,400 pounds of force at sea level. The liquid hydrogen fuel and liquid oxygen oxidizer were stored in the ET and supplied the SSMEs with propellant from approximately 6 seconds before liftoff until Main Engine Cut Off (MECO) and jettisoned, approximately 8 minutes, and 30 seconds after launch. Under the influence of gravity, the ET would fall towards Earth, eventually disintegrating as it reentered Earth's atmosphere.

After MECO and ET jettison the SSMEs were no longer used. The shuttle relied on the Orbital Maneuvering System (OMS) and the Reaction Control System (RCS) during the orbital phase for velocity changes. The OMS was located in two pods on the aft section of the Orbiter at the base of the vertical stabilizer. The pods also contained the aft RCS. The forward RCS was located just past the nose of the Orbiter. The RCS was used for small velocity and orientation adjustments and the two OMS engines were used for large velocity changes.

The Shuttle was designed to transport payloads into low Earth orbit, between 100 and 300 nautical miles, and have nominal mission durations of 4 to 16 days in space. The Orbiter provided accommodation to up to seven astronauts,

four seated on the flight deck during the launch while another three were seated in the mid-deck area, although eight astronauts flew on STS-84. After orbital insertion the flight deck, mid deck, additional hardware and software were configured for on-orbit activities.

At the conclusion of orbital operations the payload bay doors were closed, the Orbiter was turned to a tail-first attitude, the OMS engines were fired to reduce the Orbiter's velocity and permit deorbit, then it was turned back to a nose-first attitude for reentry. During reentry the aft RCS was used to control the roll, pitch and yaw until the atmospheric density was sufficient for the aero surfaces to become effective. The Orbiter would perform a series of banking maneuvers, using atmospheric drag, to decrease its velocity. Combined with the descent angle and continued drag these maneuvers reduced the velocity to about 230 mph at main landing gear touchdown.

Spacecraft recovery operations began as soon as the Orbiter stopped rolling. Ground support personnel, wearing protective gear, approached the vehicle with sensors to determine if the area around the Orbiter was safe. After determining the area safe for operations, ground support equipment was attached to the orbiter to begin purging systems, dissipating reentry heat and preparing for crew egress. After crew egress the spacecraft was powered down and transported to the Orbiter Processing Facility. If the shuttle landed at sites other than Kennedy Space Center (KSC) the spacecraft was carefully inspected and prepared for mating to the Shuttle Carrier Aircraft and ferried back to KSC for further processing and prelaunch preparations for its next scheduled mission.

This recording project is part of the Historic American Engineering Record (HAER), a long-range program to document historically significant engineering, industrial, and maritime works in the United States. The HAER program is administered by the National Park Service, U.S. Department of the Interior. The Space Transportation System recording project was cosponsored during 2011 by the Space Shuttle Program Transition and Retirement Office of the Johnson Space Center (JSC), with the guidance and assistance of Barbara Severance, Integration Manager, JSC, Jennifer Groman, Federal Preservation Officer, NASA Headquarters and Ralph Allen, Historic Preservation Officer, Marshall Space Flight Center. The field work and measured drawings were prepared under the general direction of Richard O'Connor, Chief, Heritage Documentation Programs, National Park Service. The project was managed by Thomas Behrens, HAER Architect and Project Leader. The Space Transportation System Recording Project consisted architectural delineators, John Wachtel, Iowa State and Joseph Klimek, Illinois Institute of Technology. This documentation is based on high-definition laser scans provided by Smart GeoMetrics, Houston, Texas and documentation provided by NASA's Headquarters, Johnson Space Center and Marshall Space Flight Center. Written historical and descriptive data was provided by Archaeological Consultants Inc., Sarasota, Florida. Large-format photographs were produced by NASA's Imaging Lab at Johnson Space Center with supplemental images provided by Jet Lowe, HAER photographer.

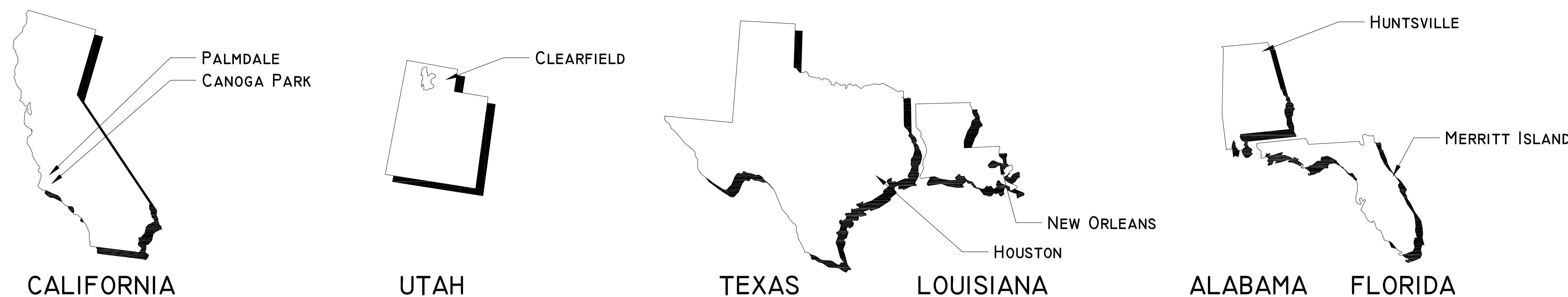

FULL STACK ISOMETRIC

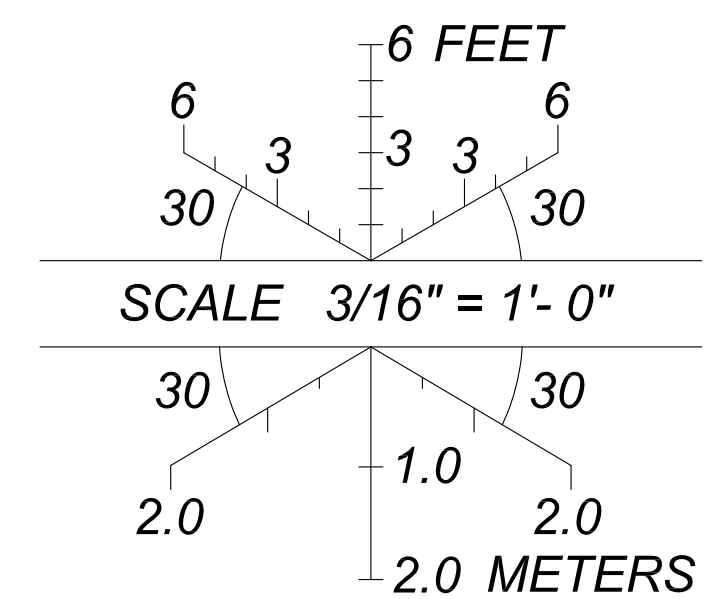
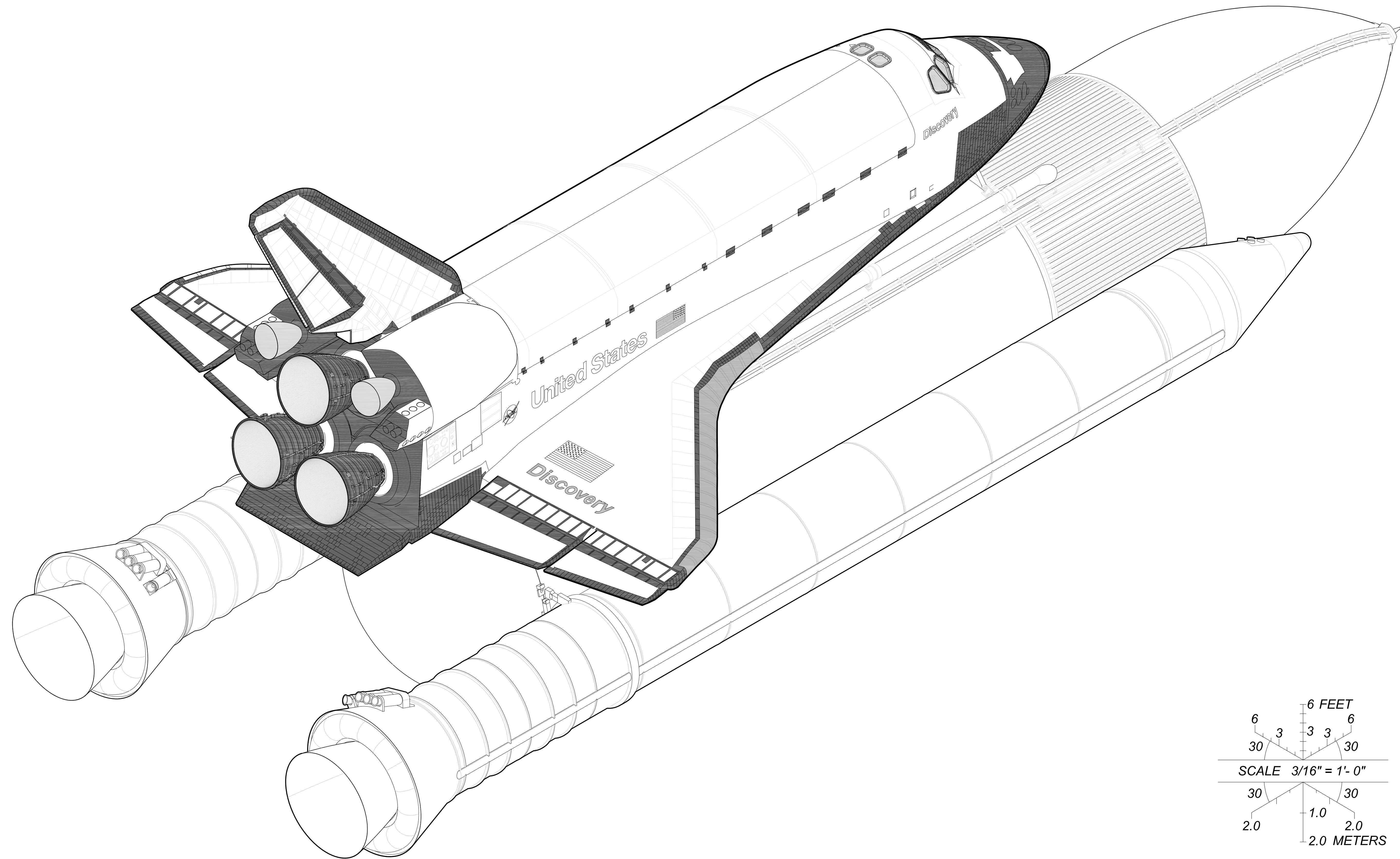

DELINEATED BY: JOHN WACHTEL, JOSEPH KLIMEK
 SPACE TRANSPORTATION SYSTEM
 RECORDING SERVICE
 NATIONAL PARK SERVICE
 UNITED STATES DEPARTMENT OF THE INTERIOR

HOUSTON
 HARRIS COUNTY
 TEXAS
 SPACE TRANSPORTATION SYSTEM, ORBITER DISCOVERY (OV-103)
 JOHNSON SPACE CENTER, 2101 NASA PARKWAY

HISTORIC AMERICAN
 ENGINEERING RECORD

SHEET
 2 OF 6

TX-116-A

IF REPRODUCED, PLEASE CREDIT THE HISTORIC AMERICAN ENGINEERING RECORD, NATIONAL PARK SERVICE, NAME OF DELINEATOR, DATE OF DRAWING

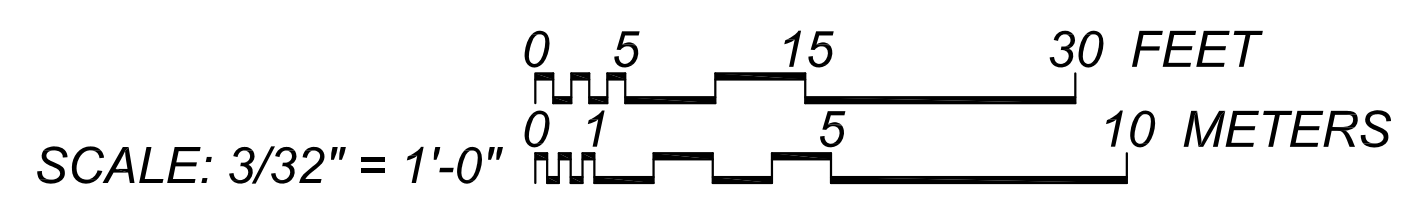
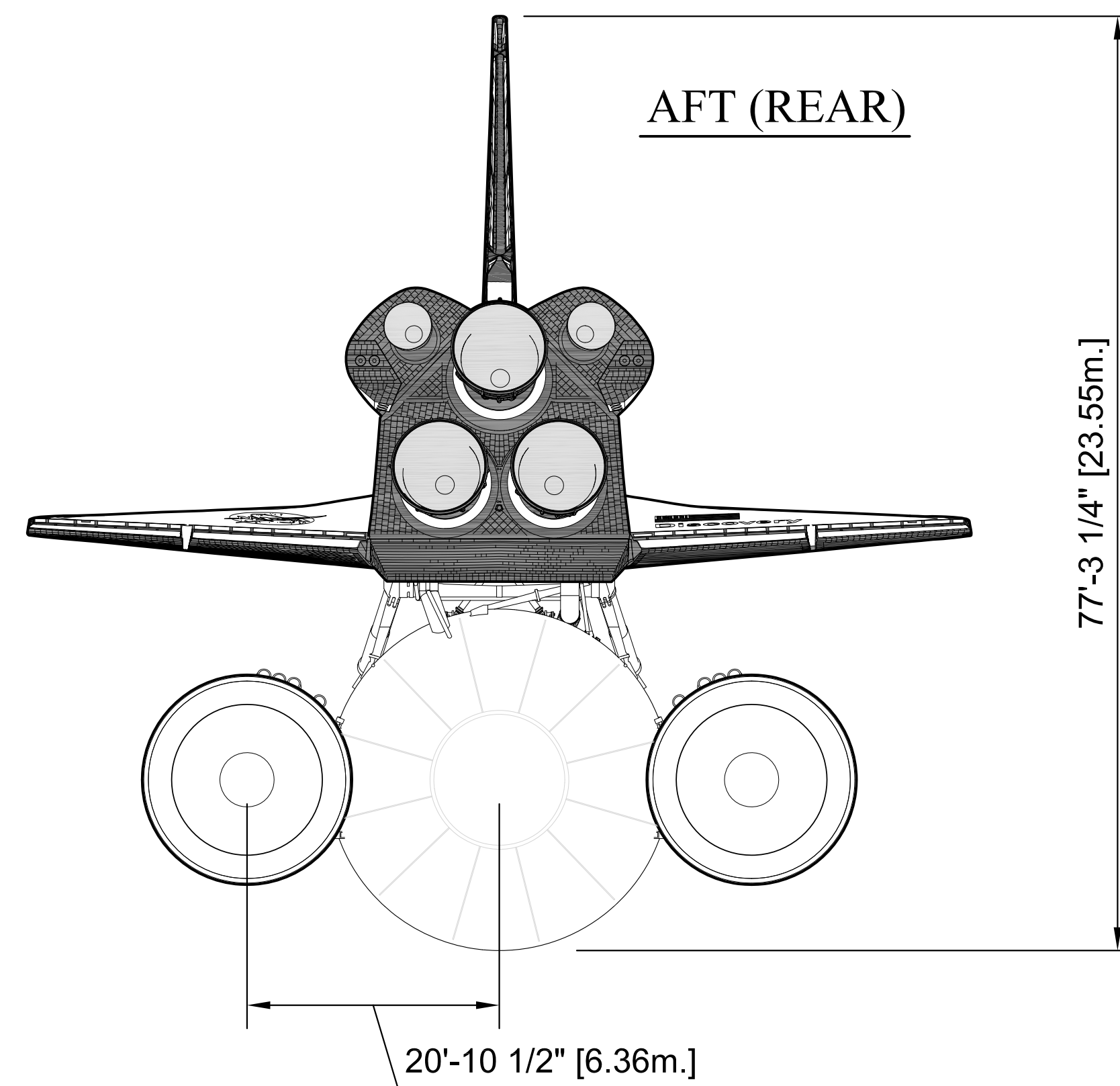
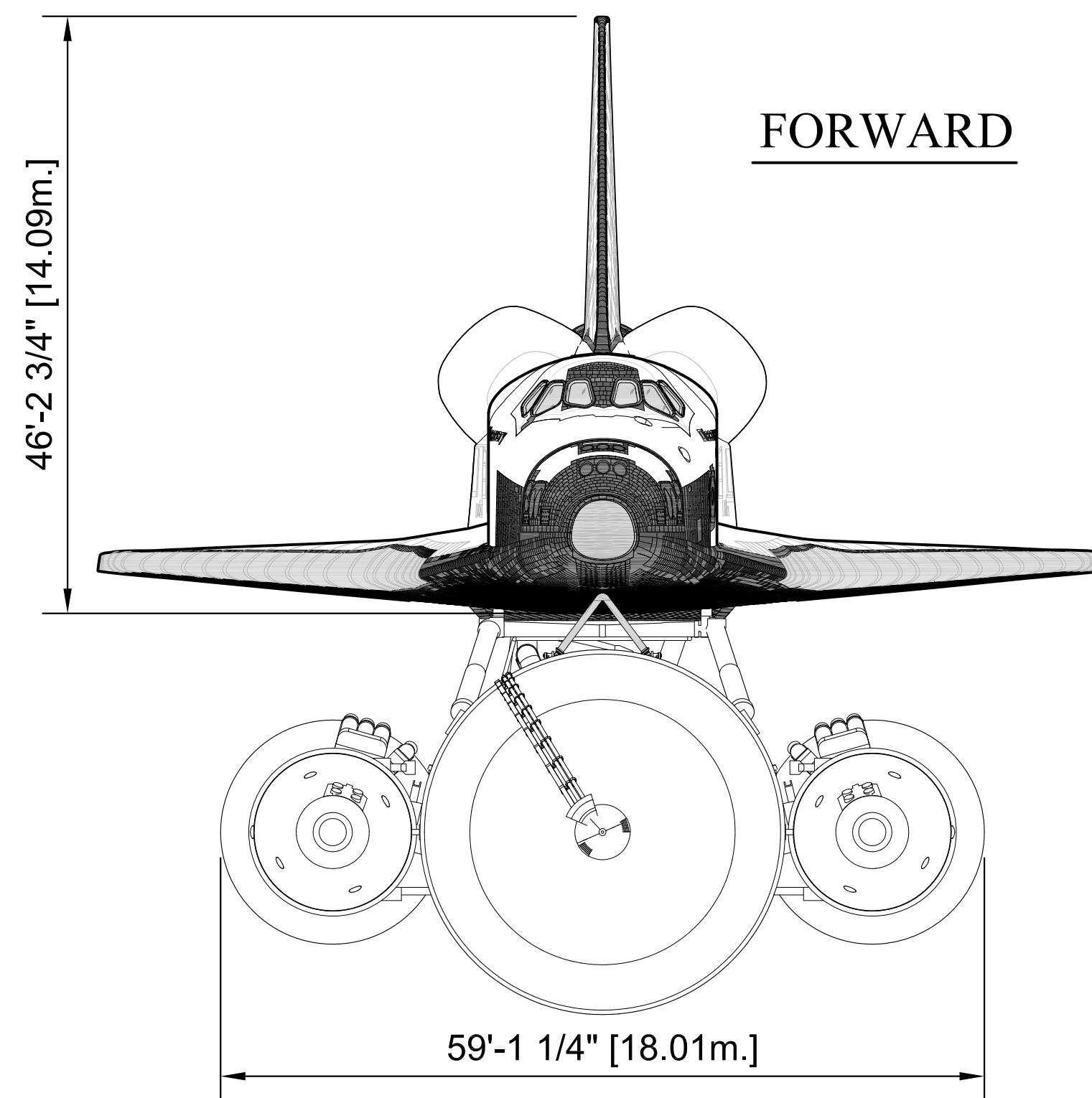
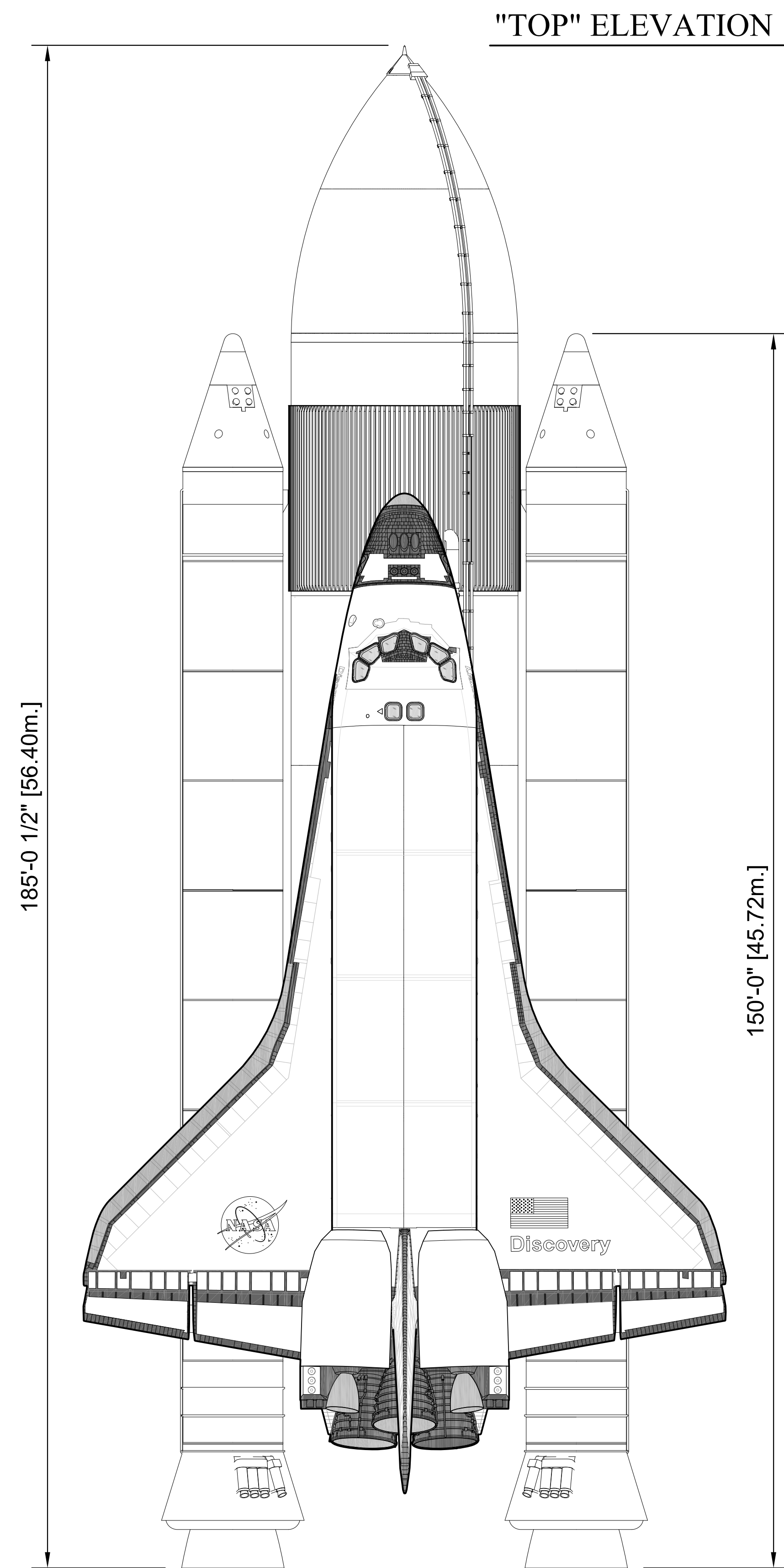

FULL STACK ELEVATIONS

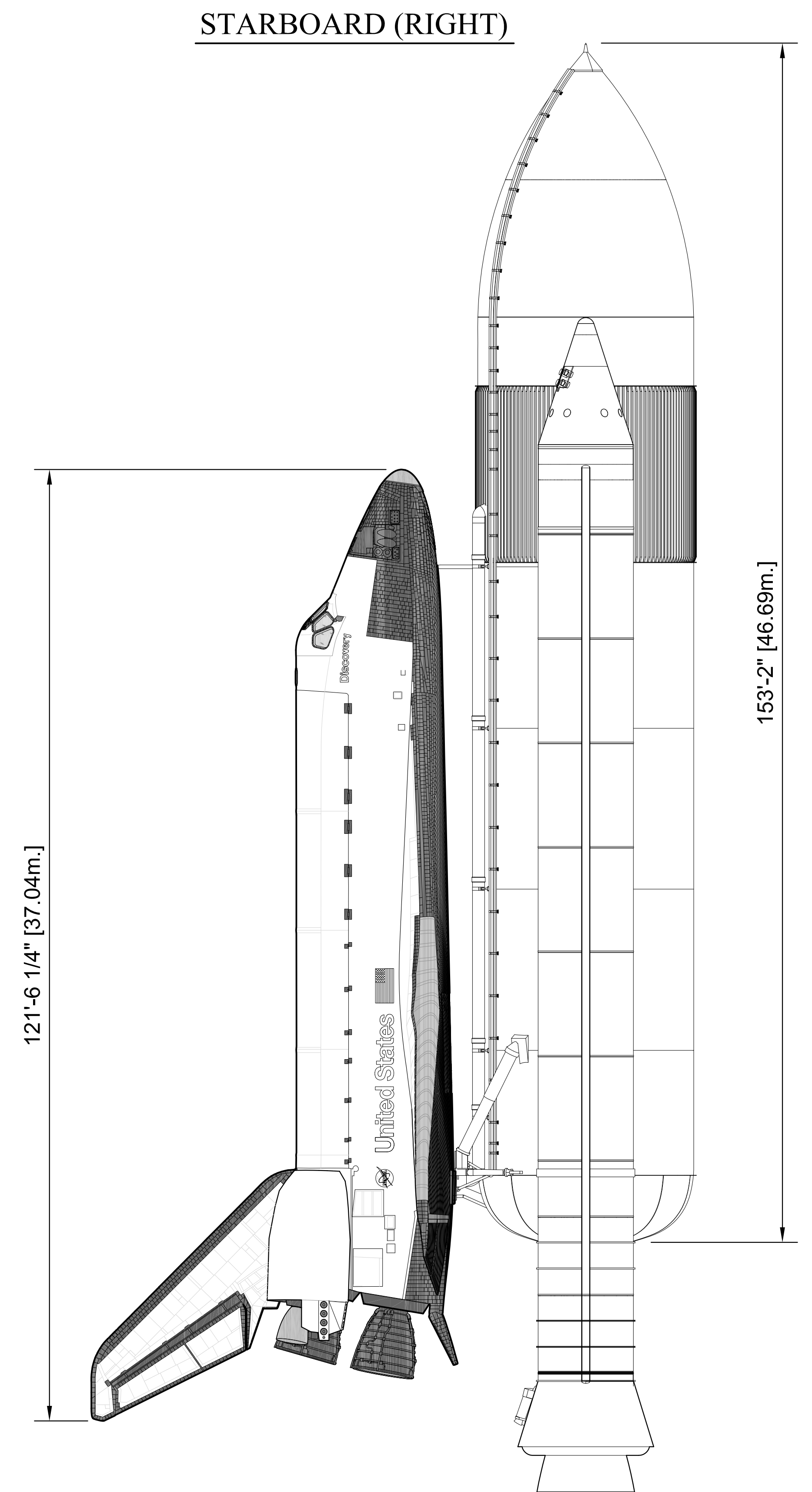

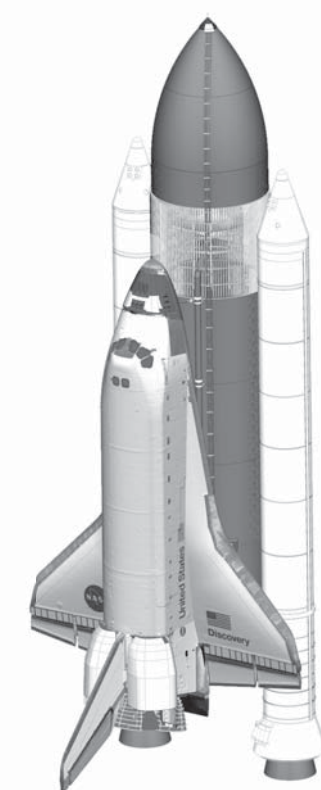

(A) LAUNCH
T+: 00:00:00

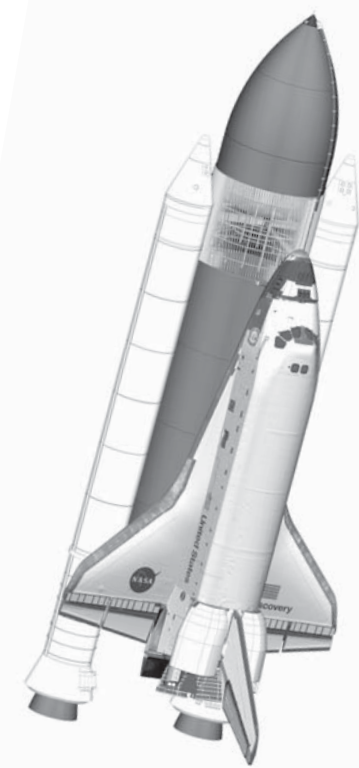

(B) PITCH + ROLL
T+: 00:00:11 - 18

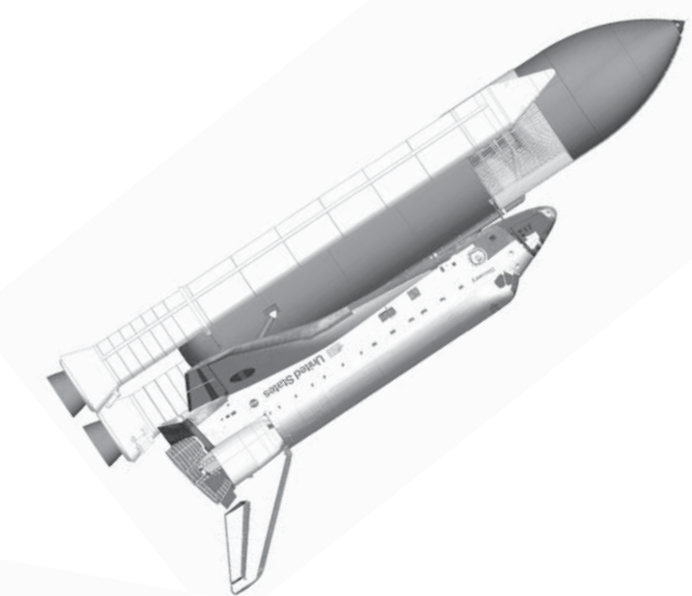

(C) SRB STAGING
T+: 00:02:03

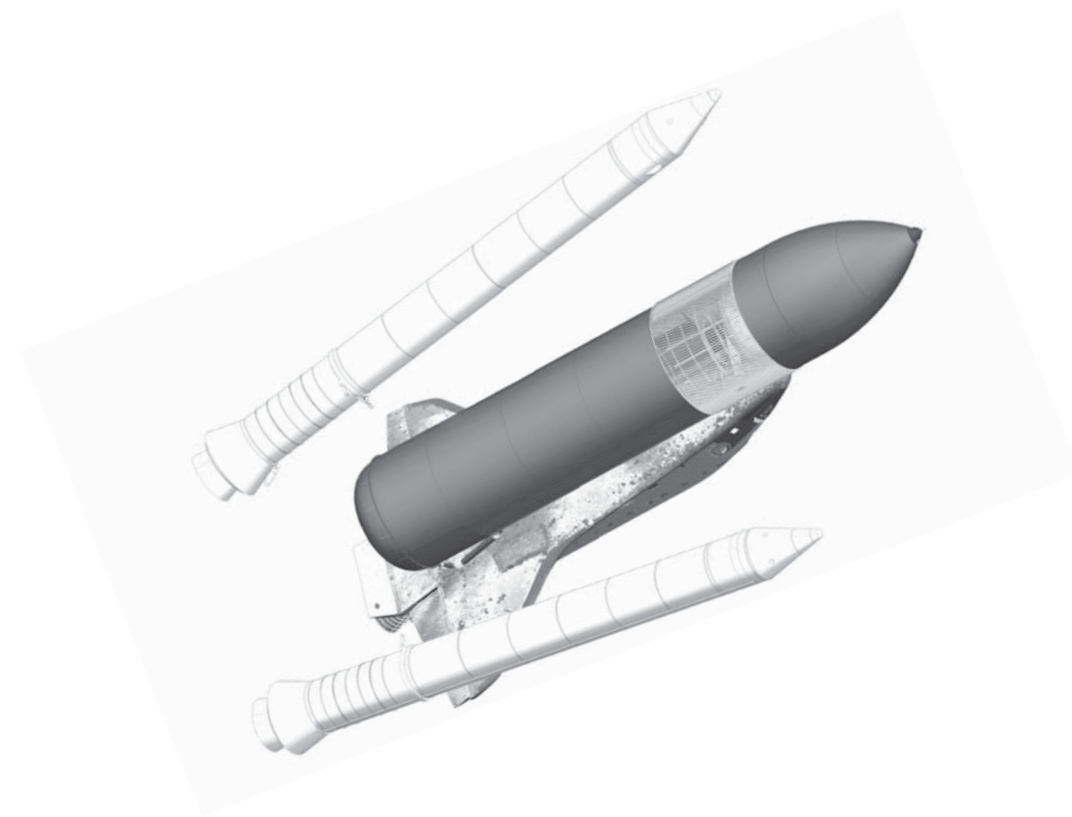

(D) ROLL TO HEADS UP
T+: 00:03:53-28

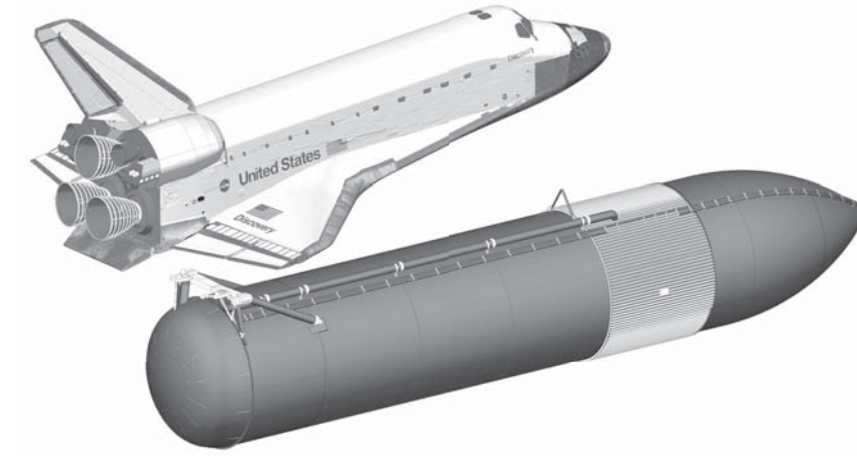

(E) / (F) MECO/ ET SEPARATION
T+: 00:08:24/ T+: 00:08:33

(G) APOGEE (OMS BURN #2)
T+: 00:38:14



(H) PAYLOAD BAY DOOR OPENING
T+: 01:00:00

STS FLIGHT LAUNCH MISSION PROFILE

THE FLIGHT LAUNCH MISSION PROFILE COVERS THE LAUNCH OPERATIONS FROM COUNTDOWN TO SPACE STATION RENDEZVOUS.

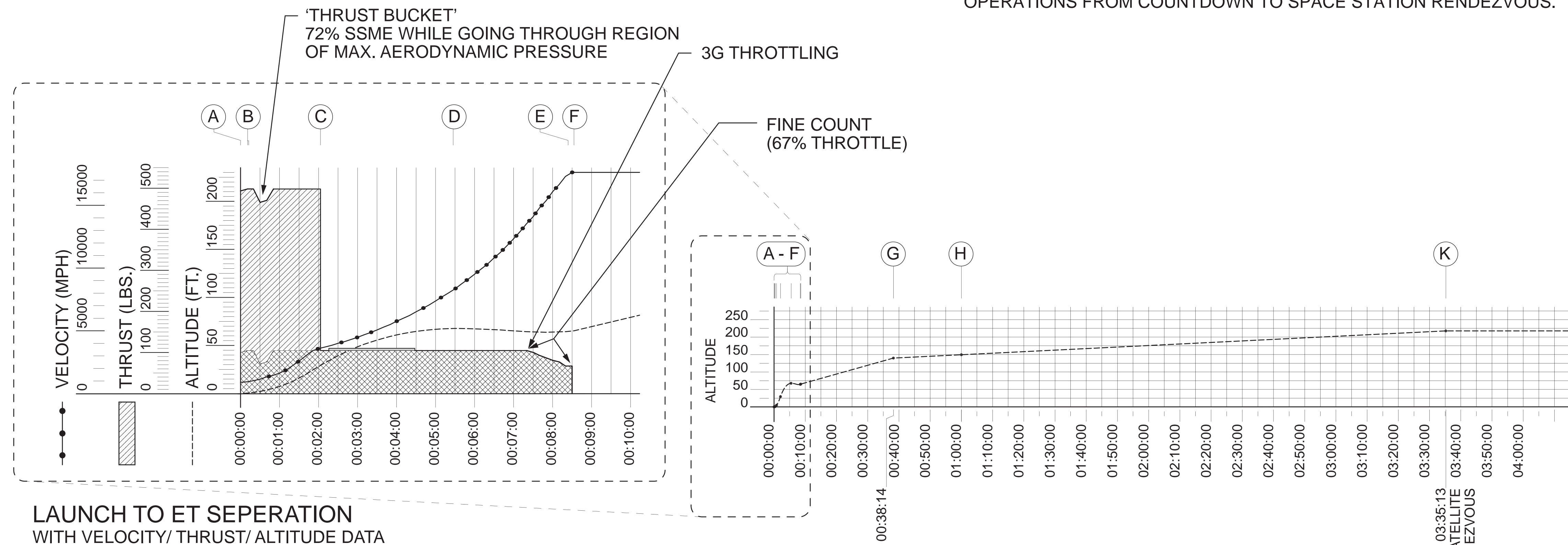

[Hatched Box] THRUST - SRB
 [Cross-hatched Box] THRUST - SSME
 [Solid Grey Box] THRUST - OMS PODS

DELINEATED BY: JOHN WACHTEL, JOSEPH KLIMEK
 SPACE TRANSPORTATION SYSTEM
 RECORDING PROJECT
 NATIONAL PARK SERVICE

UNITED STATES DEPARTMENT OF THE INTERIOR

HOUSTON

SPACE TRANSPORTATION SYSTEM
 JOHNSON SPACE CENTER, 2101 NASA PARKWAY
 HARRIS COUNTY

TEXAS 4 OF 6

HISTORIC AMERICAN
 ENGINEERING RECORD

LIBRARY OF CONGRESS
 PHOTODUPLICATION SERVICE

TX-116-J

IF REPRODUCED, PLEASE CREDIT THE HISTORIC AMERICAN ENGINEERING RECORD, NATIONAL PARK SERVICE, NAME OF DELINEATOR, DATE OF DRAWING

POST ATMOSPHERIC INSERTION PROCESS

- 1) RECONFIGURE TO ON-ORBIT SOFTWARE AND GPC CONFIG.
- 2) ACTIVATE RADIATORS.
- 3) OPEN PAYLOAD BAY DOORS.
- 4) PURGE THE FUEL CELLS.
- 5) LOFT AND STOW LES, RECONFIGURE COCKPIT FOR ORBIT OPERATIONS.



DE-ORBIT BURN
 DIST : 28,865 km (12,966 miles)
 ALT. : 282 km (175 miles)
 SPD. : 26,498 km/h (16,465 mph)

END - POST INSERTION PROCESS

BEGIN - PHASE I: ENTRY INTERFACE

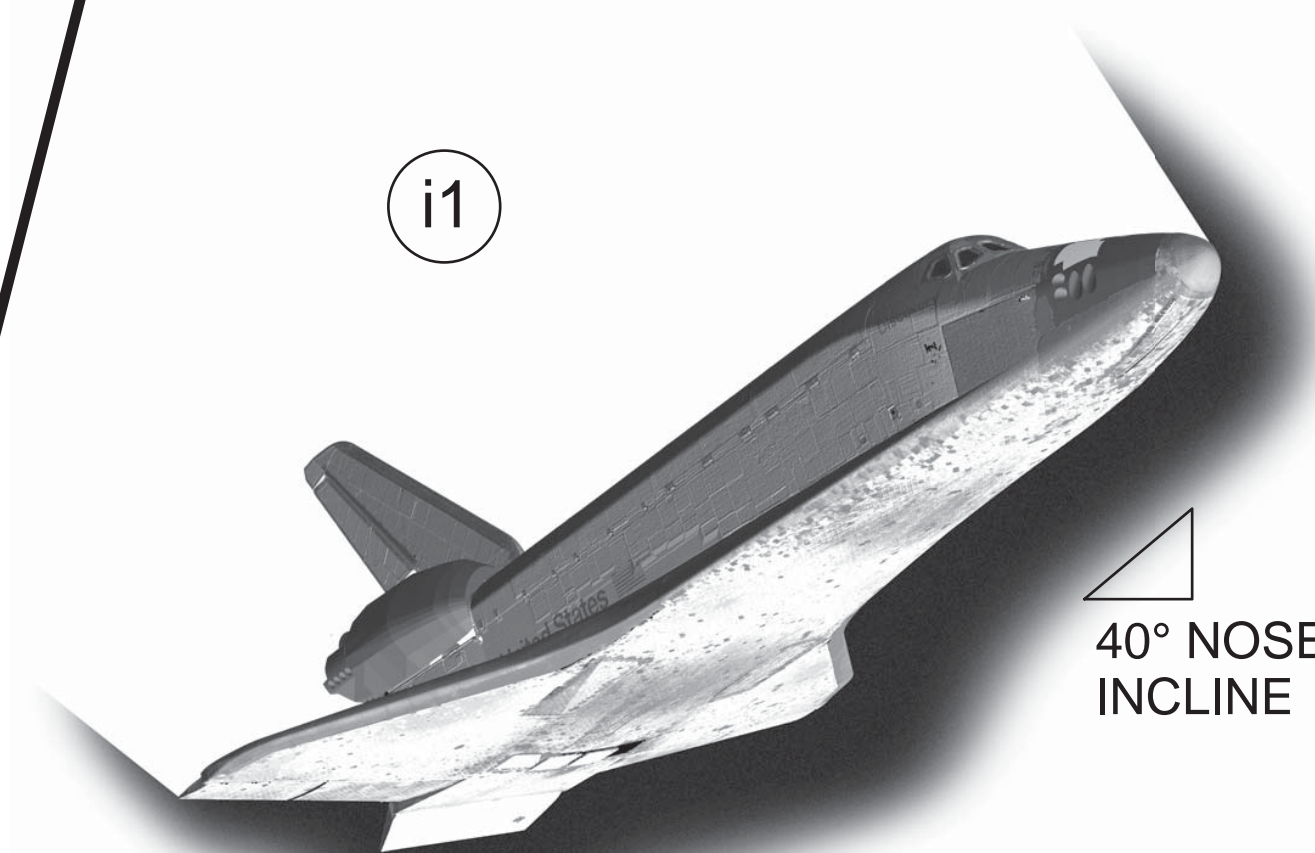

- i1 - NOSE INCLINE
- i2 - BANK MANEUVERS
- i3 - CONSTANT DRAG PHASE
- i4 - TRANSITION PHASE

AT PHASE I BEGIN:
 DIST : 7,600 km (4,722 miles)
 ALT. : 122 km (76 miles)
 VEL. : 25,898 km/h (16,093 mph)

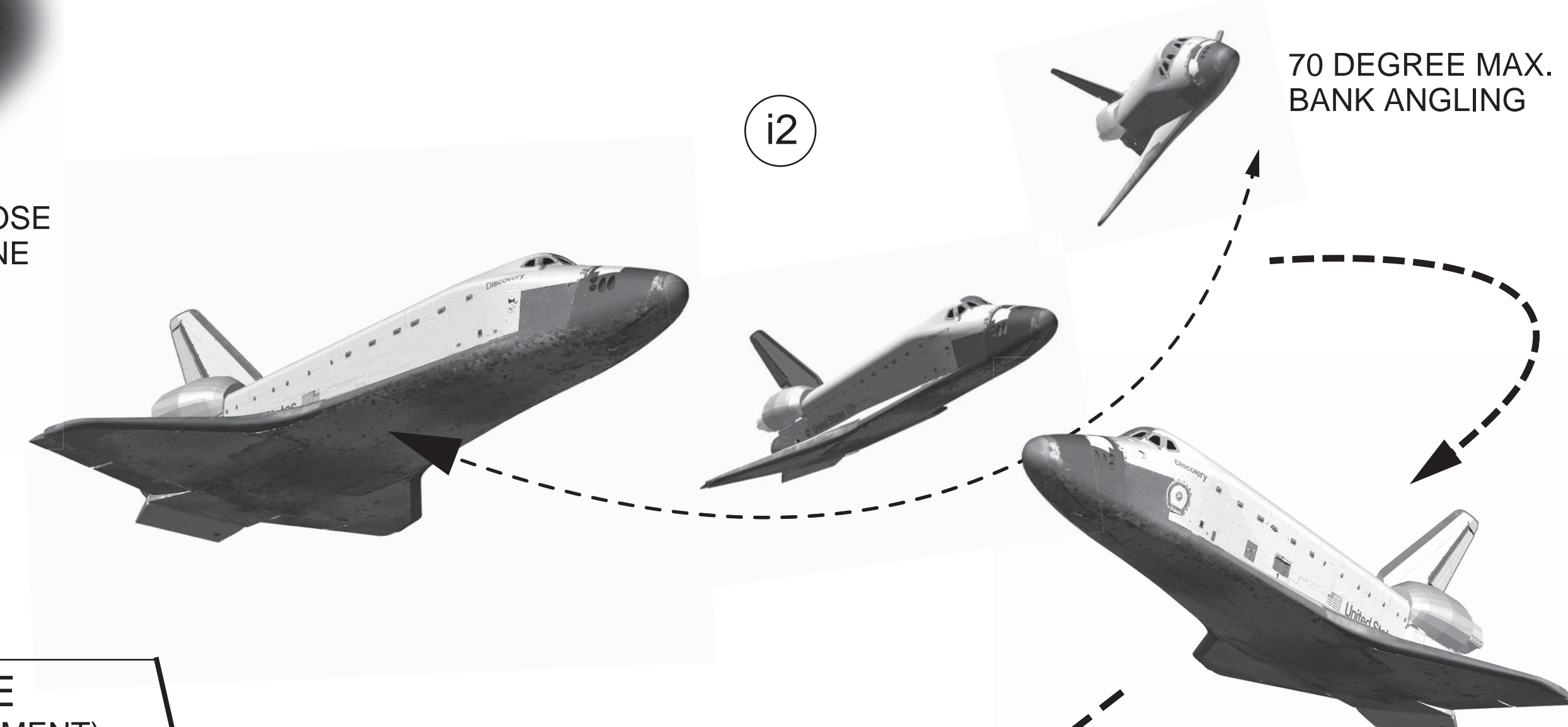

END - PHASE I

BEGIN - PHASE II: TAEM INTERFACE (TERMINAL AREA ENERGY MANAGEMENT)

- ii1 - S-TURN MANEUVER
- ii2 - ACQUISITION
- ii3 - HEADING ALIGNMENT
- ii4 - PREFINAL

AT PHASE II BEGIN:
 DIST : 90 km (56 miles)
 ALT. : 24 km (15 miles)
 VEL. : 2700 km/h (1,678 mph)

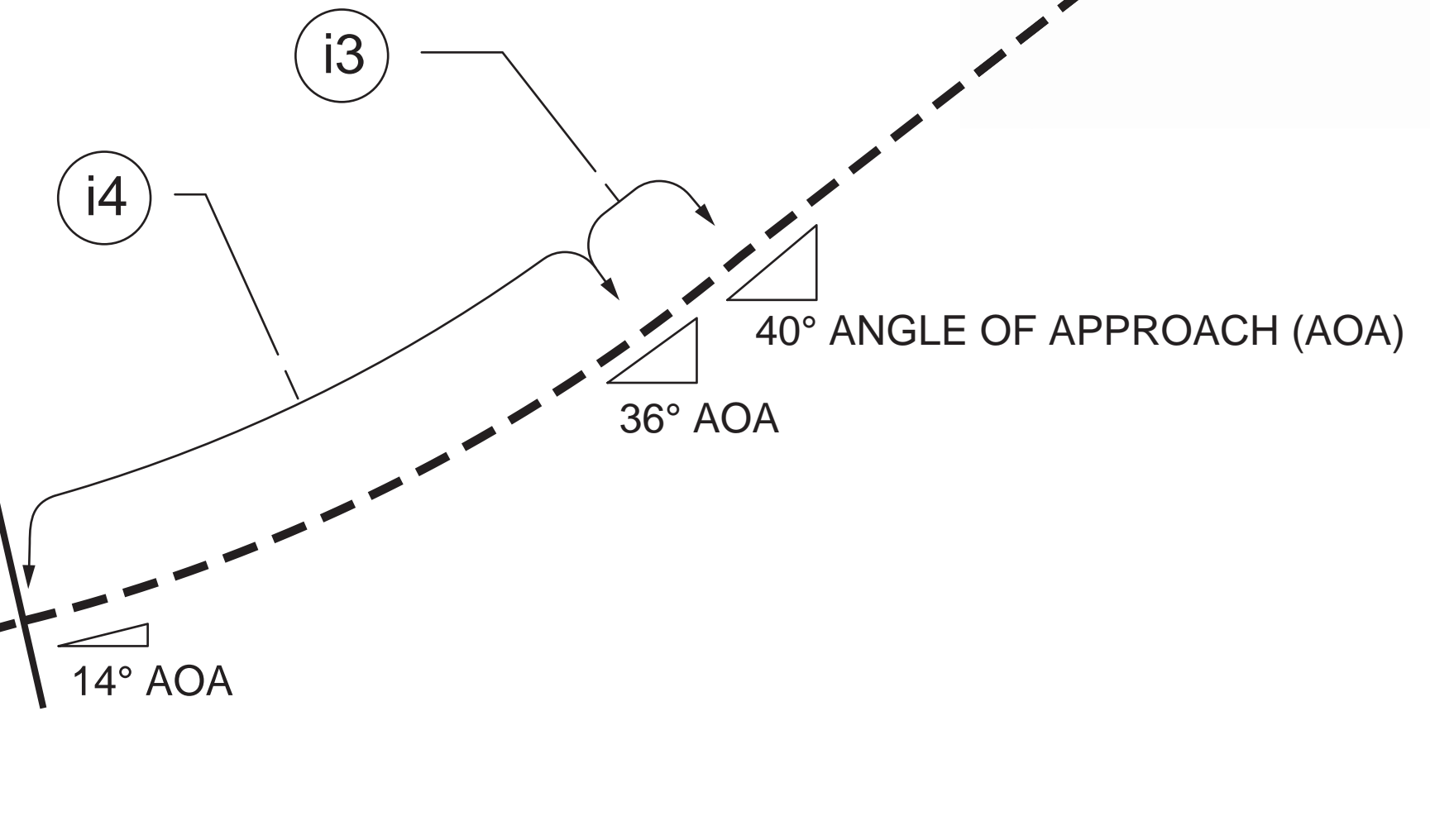
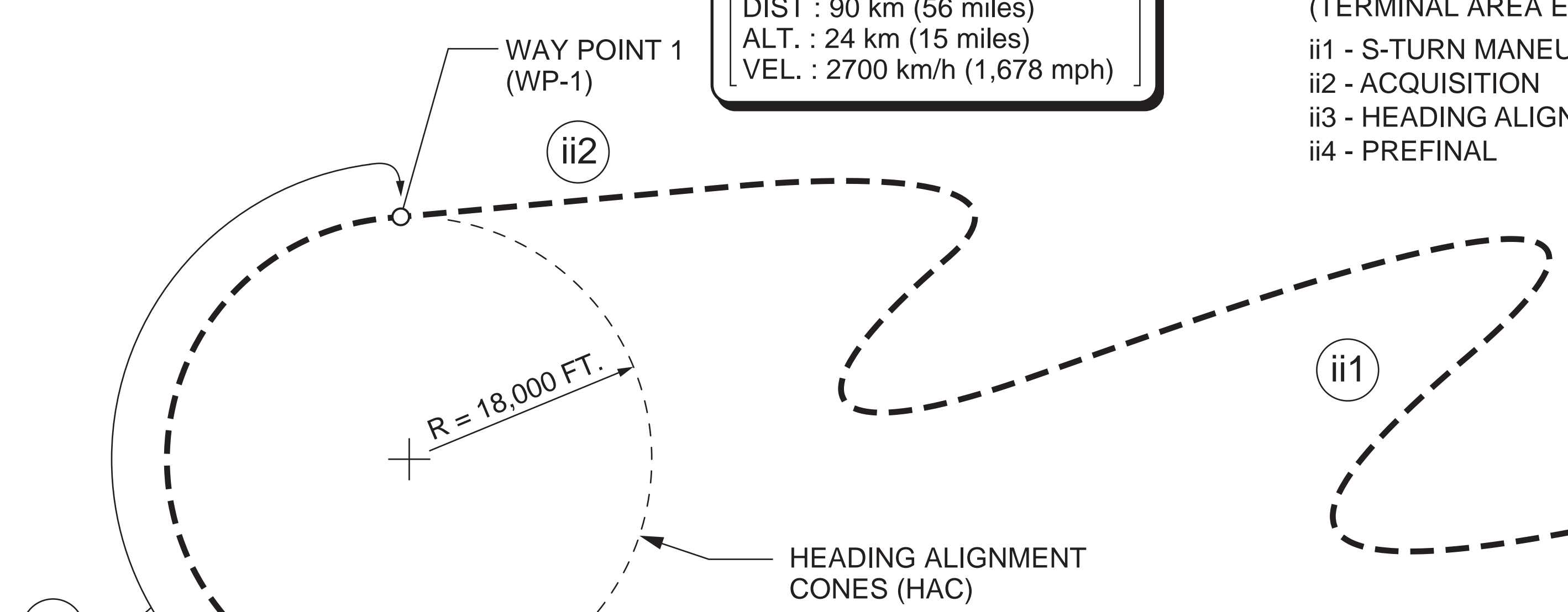

END - PHASE II

BEGIN - PHASE III: APPROACH + LANDING

- iii1 - TRAJECTORY CAPTURE
- iii2 - OUTER GUIDESLOPE (OGS)
- iii3 - PREFLARE + INNER GUIDESLOPE (IGS)
- iii4 - FINAL FLARE
- iii5 - TOUCHDOWN

AT PHASE III BEGIN:
 DIST : 12 km (7.5 miles)
 ALT. : 3 km (1.9 miles)
 VEL. : 682 km/h (424 mph)

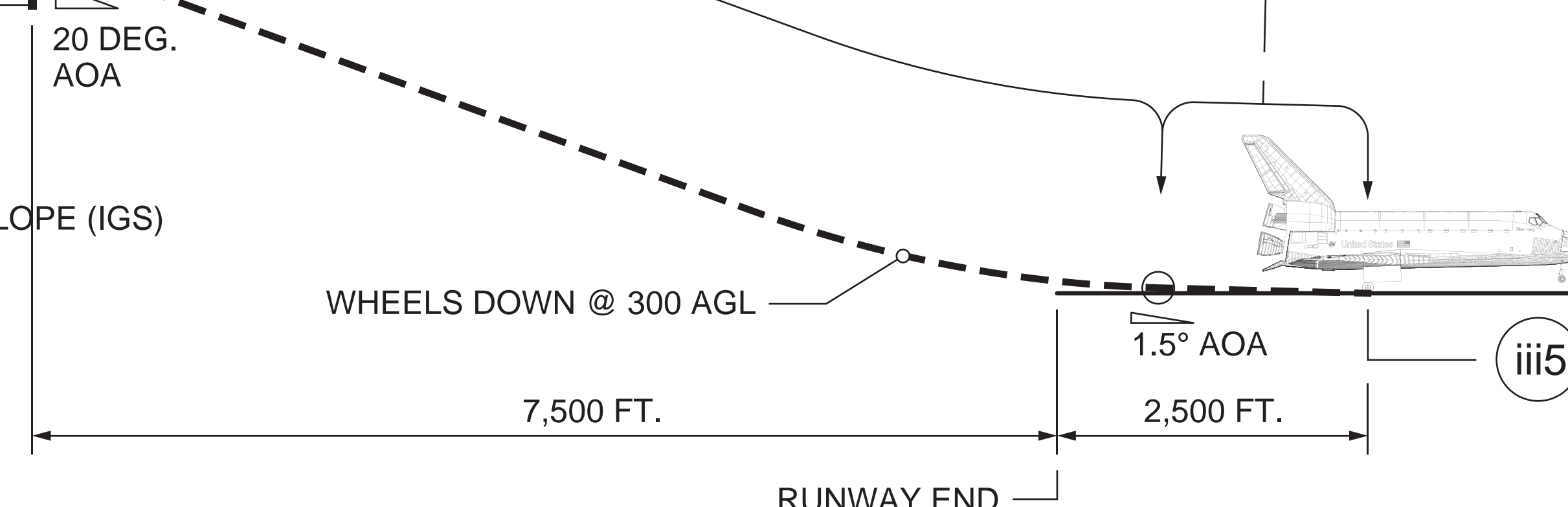

AT TOUCHDOWN
 DIST : 689 km (2,261 ft.) *FROM END OF RUNWAY
 ALT. : 0 km (0 miles)
 VEL. : 346 km/h (215 mph)

ORBITER ENTRY + LANDING

POST INSERTION PROCESS
 PHASE I: ENTRY INTERFACE.
 PHASE II: TAEM INTERFACE.
 PHASE III: APPROACH + LANDING.

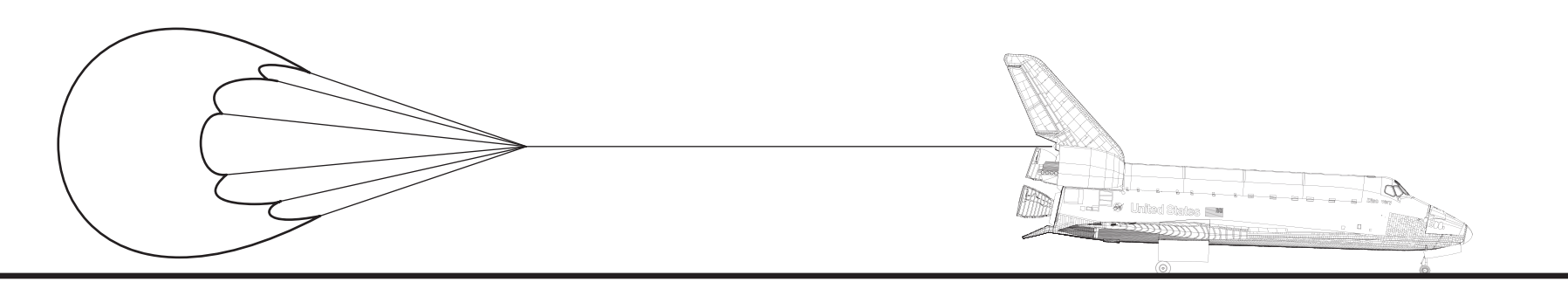

*THIS PAGE IS NOT DRAWN TO SCALE

RELEASED - Printed documents may be obsolete; validate prior to use.

SRB RECOVERY & REFURBISHMENT

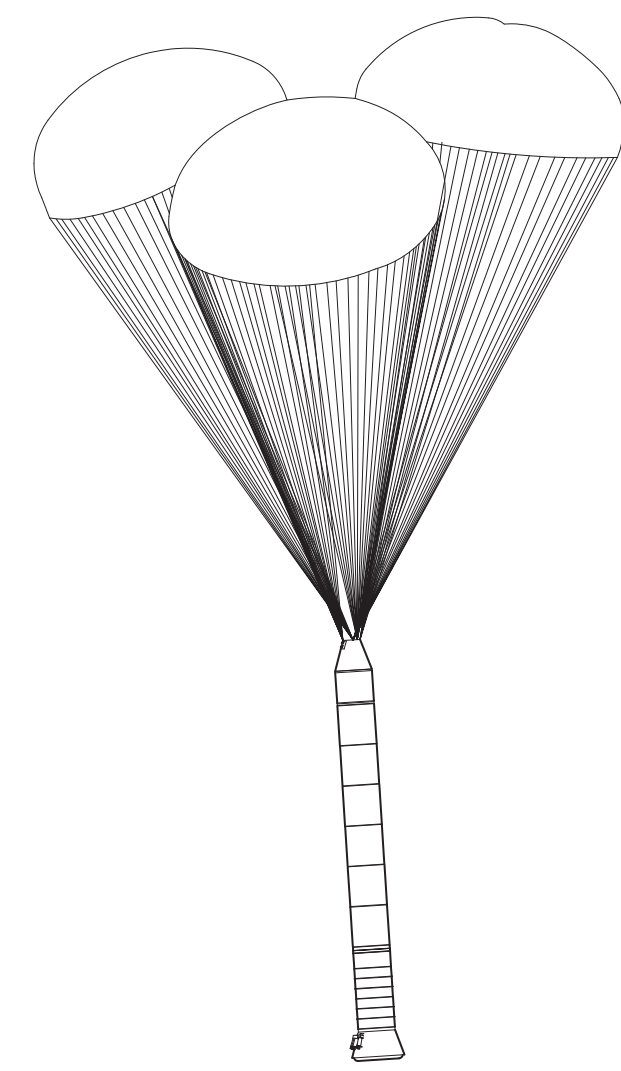

After the Solid Rocket Booster (SRB) separated from the stack they begin their fall towards the ocean. At a predetermined altitude, parachutes were deployed to lessen the impact of splashdown. Two recovery ships, "Freedom Star" and "Liberty Star", with their crews, recovered and returned the SRBs to KSC for processing.

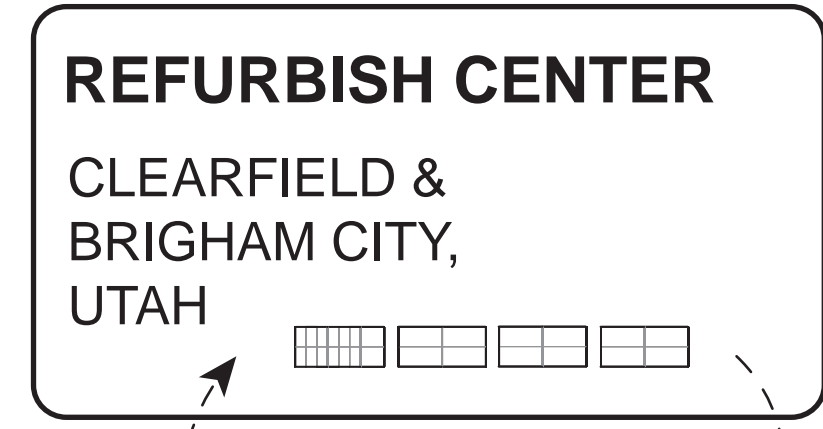
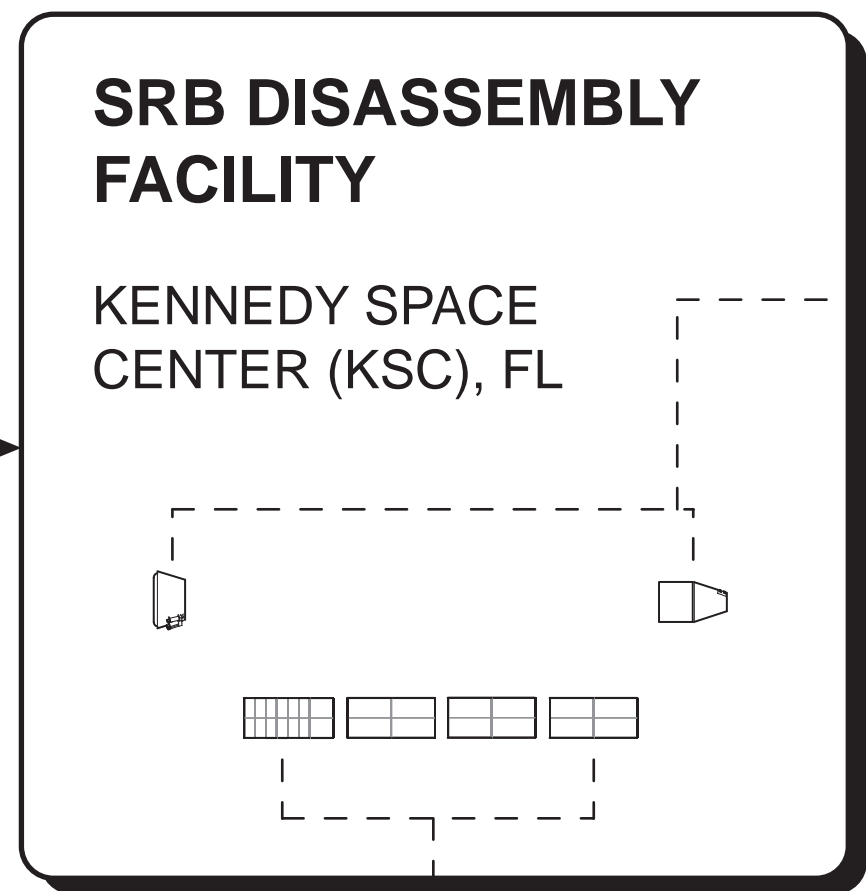
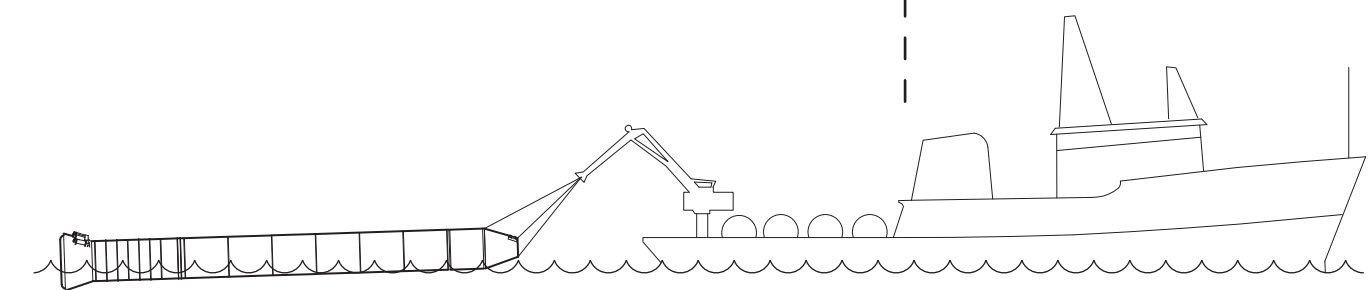

BY RAIL TO UTAH FACILITY

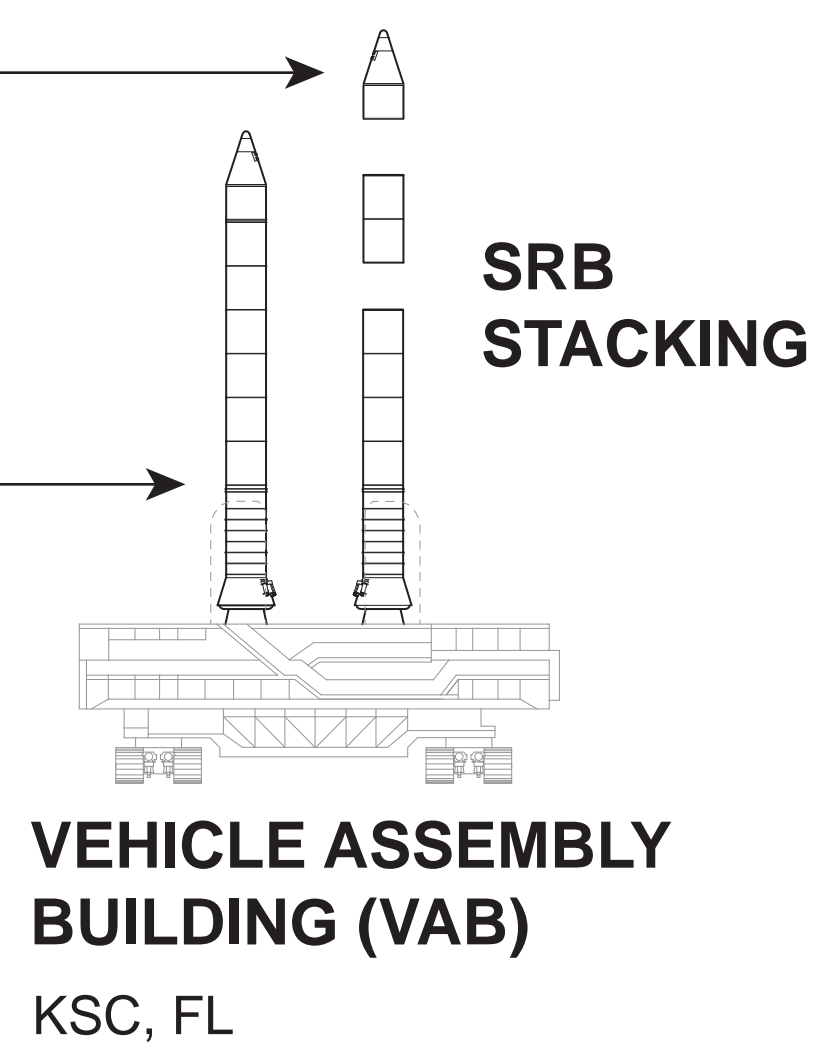
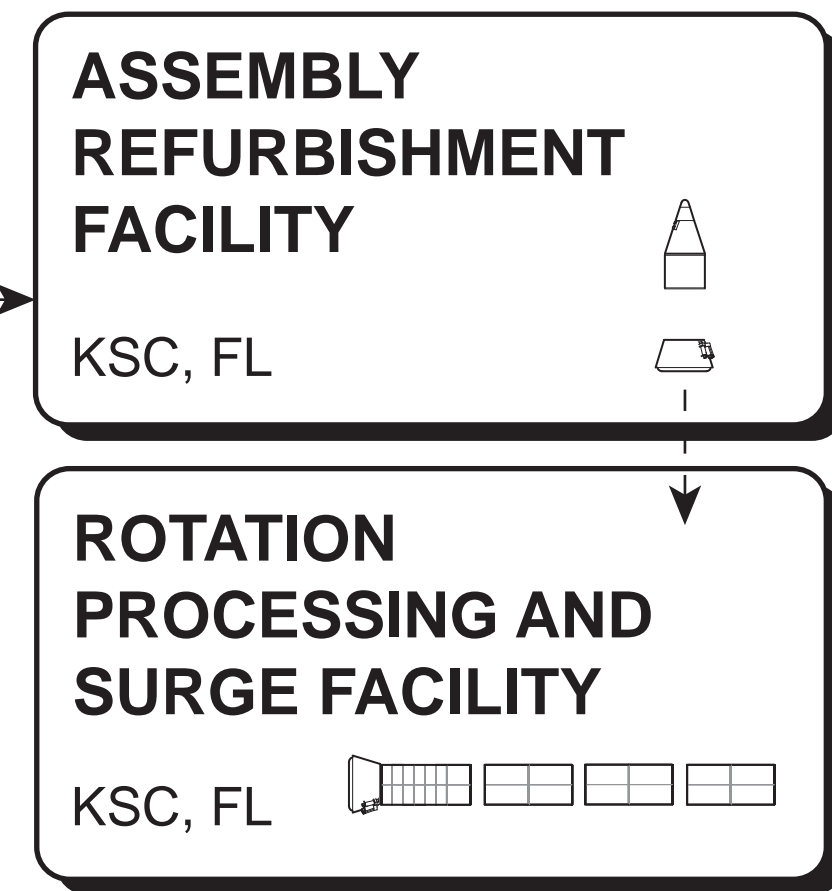

EXTERNAL TANK DELIVERY

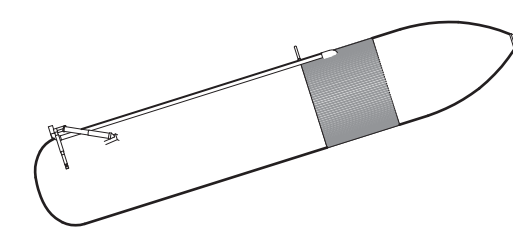

EXTERNAL TANK RE-ENTRY BREAK UP

After the Main Engine Cut Off sequence the External Tank (ET) was jettisoned on command from the orbiter. The ET descended under the influence of Earth's gravity and disintegrated as it reentered the atmosphere. The Michoud Assembly Facility in New Orleans fabricated new ETs for each Shuttle Launch and shipped them by barge to Kennedy Space Center.



BARGE TRANSPORTATION

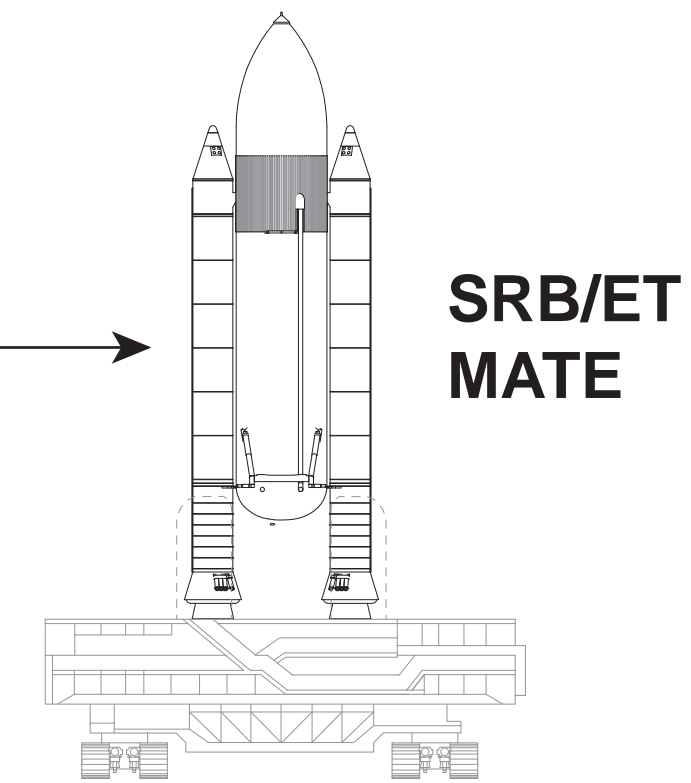
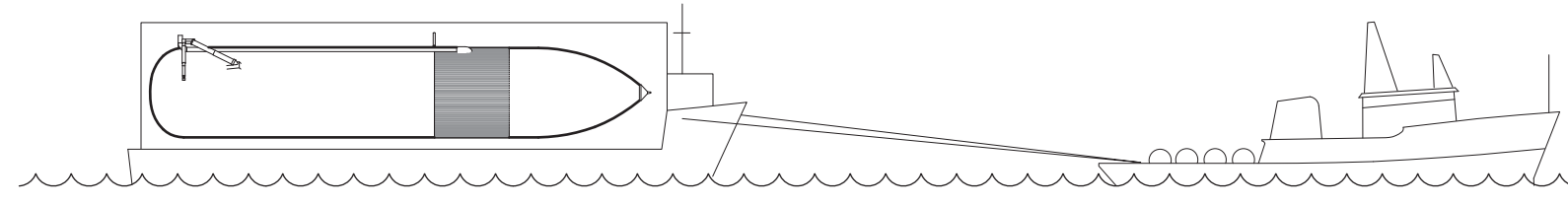

SHUTTLE TURNAROUND & TRANSPORT

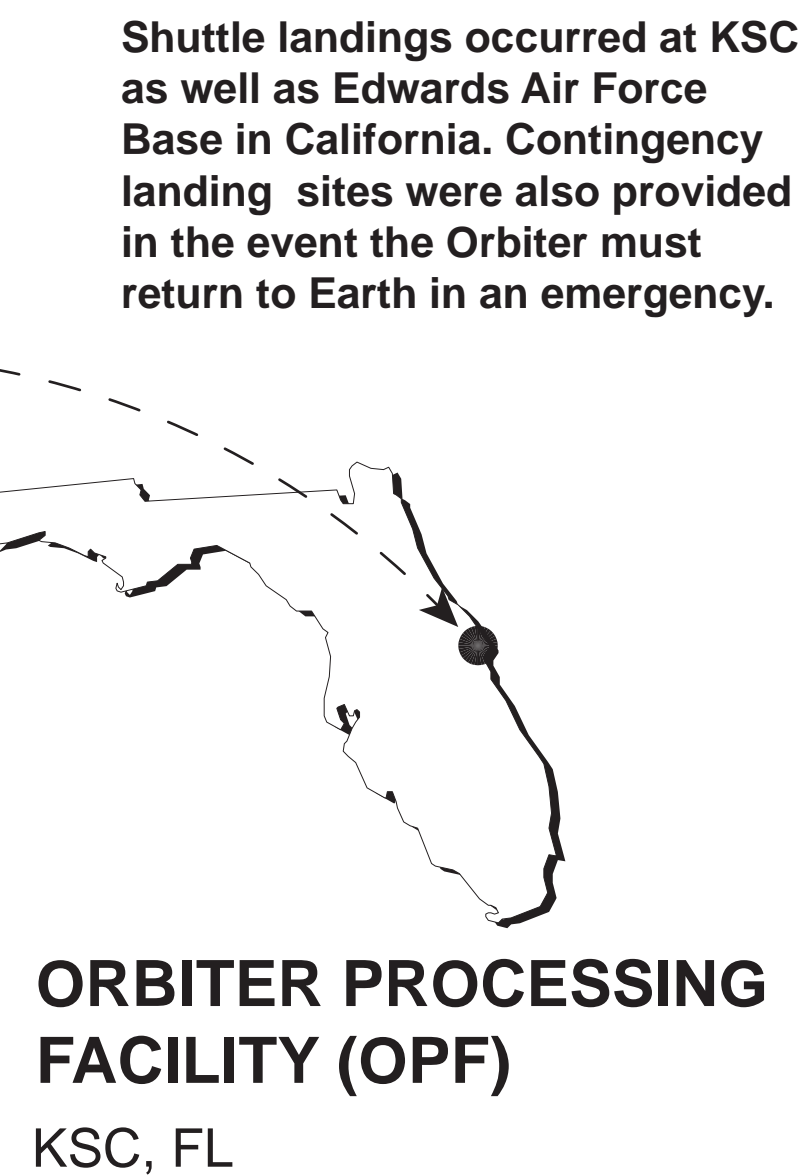

Spacecraft recovery operations began immediately after wheel stop. Systems were secured, crews disembarked, payloads, hazardous components and propulsion elements were removed, inspected and/or refurbished. Afterwards, pre-mate preparations began for the next mission for that Orbiter.

